

Rexroth Rho 4 Machine parameters

1070072175
Edition 07

Project planning



Title Rexroth Rho 4
Machine parameters

Type of Documentation Project planning

Document Typecode DOK-RHO*4*-MASCH*PAR**-PR07-EN-P

Purpose of Documentation The present manual informs about:

- Adjustment of the rho4 machine parameters
- The handling of the MPP–editor and –converter

Record of Revisions

Description	Release Date	Notes
DOK-RHO*4*-MASCH*PAR**-PR06-EN-P	10.2003	Valid from VO07
DOK-RHO*4*-MASCH*PAR**-PR07-EN-P	01.2005	Valid from VO08

Copyright © Bosch Rexroth AG, 1998 – 2005
Copying this document, giving it to others and the use or communication of the contents thereof without express authority, are forbidden. Offenders are liable for the payment of damages. All rights are reserved in the event of the grant of a patent or the registration of a utility model or design (DIN 34–1).

Validity The specified data is for product description purposes only and may not be deemed to be guaranteed unless expressly confirmed in the contract. All rights are reserved with respect to the content of this documentation and the availability of the product.

Published by Bosch Rexroth AG
Postfach 11 62
D-64701 Erbach
Berliner Straße 25
D-64711 Erbach
Tel.: +49 (0) 60 62/78-0
Fax: +49 (0) 60 62/78-4 28
Abt.: BRC/ESH (KW)

Overview of all manuals

Overview of all manuals

Manual	Contents
Connection conditions Rho 4.0	2 System overview
	3 Installation
	4 Electrical connection
	5 Interfaces
	6 LED display
	7 Maintenance and replacement
	8 Order numbers
System description Rho 4.0	2 System overview
	3 Structure of the rho4.0
	4 PCLrho4.0
	5 CAN-Bus peripheral unit
	6 SERCOS interface
	7 Software
	8 File management
Connection conditions Rho4.1, Rho 4.1/IPC300	2 System overview
	3 Security functions
	4 Installation
	5 Electrical connection
	6 Interfaces
	7 LED display
	8 Maintenance and replacement
	9 Software
	10 Order numbers
Connection conditions Rho 4.1/BT155, Rho 4.1/BT155T, Rho 4.1/BT205	2 System overview
	3 Security functions
	4 Installation
	5 Electrical Connections
	6 Interfaces
	7 Display and Operating Controls
	8 Maintenance and Replacemant
	9 Software
	10 Order numbers
System description Rho 4.1	2 Structure of the rho4.1
	3 PCL
	4 CAN-Bus peripheral unit
	5 SERCOS interface

Overview of all manuals

Manual	Contents
	6 Software
	7 File management
	8 Scope of the rho4.1 Software

Manual	Contents
Control functions	2 Survey of special functions
	3 Accurate position switching
	4 Setting the machine position
	5 Calling operating system functions
	6 Parameterization of the belt characteristic
	7 Selecting a point-file
	8 Mirroring
	9 Belt type
	10 System date and time
	11 System counter
	12 WC main range
	13 Setting the belt counter
	14 Recording of reference path
	15 Flying measurement (rho4.1 only)
	16 MOVE_FILE
	17 Setting the block preparation
	18 Exception-Handling
	19 Belt counter current value
	20 Automatic velocity adjustment for PTP movements
	21 Belt-synchronous working area belt kind 4
	22 Current belt speed
	23 Changing the belt simulation speed
	24 General functions
	25 Process-oriented functions
	26 BAPS3 keywords
	Machine parameters
3 Application of the machine parameters	
4 General system parameters	
5 Speeds	
6 Positions	
7 Kinematic parameters	

Overview of all manuals

Manual	Contents
	8 Measuring system parameters
	9 Belt parameters
	10 Drive parameters Servodyn-GC
	11 Drive parameter Servodyn-D
	12 Table of parameters
Manual	Contents
BAPS3 Programming manual	2 Program structure
	3 Constants
	4 Variables
	5 Program control
	6 Value assignments and combinations
	7 Functions
	8 Movement statement
	9 Write/read functions
	10 BAPS3 keywords
	BAPS3 Short description
3 Constants and variables	
4 Program structure	
5 Value assignments and combinations	
6 Standard functions	
7 Movements and speeds	
8 Belt synchronous	
9 Workspace limitation	
10 Write/read functions	
11 Special functions	
12 Library functions	
13 Fix files	
14 BAPS3 keywords	
Signal descriptions	
	3 Signal description of PCL inputs
	4 Signal description of PCL outputs
Status messages and warnings	2 rho4 status messages
	3 Warnings
	4 CANopen error codes
ROPS4/Online	2 General information
	3 Activation and functions of Online
	4 The function key box

Overview of all manuals

Manual	Contents
	5 Function key assignment
	6 The marker box
	7 File ROPS4WIN.ini
	8 Selection of a file
	9 TCP/IP settings for ROPS4
Manual	Contents
DLL library	2 Library functions
	3 Calling library functions in BAPS
	4 Block structure of the rho4.1
	5 Library server
	6 Application development
	7 rho4 library functions
	8 Variable access per DLL
	PHG2000
3 PHG2000 system variables	
4 Selection of PHG functions	
5 Info function of the PHG	
6 Controlling the PHG2000 output	
7 Define/Teach	
8 SRCAN functions	
9 File and User Memory Functions	
10 File list	
11 Process info	
12 Restoring the PGH display	
13 Variable assignment of PHG keys	
14 Select point file and point name	
15 BDT editor	
Connection conditions Rho 4.1/IPC 40.2	
	3 Security Functions
	4 Installation
	5 Eelectrical Connections
	6 Interface Ports & Connectors
	7 Display- and Operating Components
	8 Maintenance and Replacement
	9 Software
	10 Ordering Informations

Overview of all manuals

Manual	Contents
DDE-Server	2 Introduction
	3 Hardware and Software
	4 Operation
	5 Items of Server 4
	6 Scope of function

Overview of all manuals

Notes:

Contents

Contents

	page
1	Safety Instructions 1–1
1.1	Intended use 1–1
1.2	Qualified personnel 1–2
1.3	Safety markings on products 1–3
1.4	Safety instructions in this manual 1–4
1.5	Safety instructions for the described product 1–5
1.6	Documentation, software release and trademarks 1–7
2	General information 2–1
3	Application of the machine parameters 3–1
3.1	Application via the PHG2000 3–1
3.1.1	Input via the PHG2000 3–2
3.1.2	Changing machine parameters with the PHG2000 3–3
3.1.3	Changing the password 3–5
3.2	Kinematic selection in the machine parameter program 3–6
3.3	Machine parameter converters 3–7
3.3.1	Working principle 3–7
3.3.2	Syntax of the ASCII file 3–10
3.3.3	Initialization file MPKONV.ini 3–11
3.3.4	XMP converter 3–12
3.3.5	Dependences 3–19
3.3.6	Example for first creation of an ASCII file 3–20
3.3.7	Standard values and key words of the machine parameter converters 3–21
3.3.8	Comparison table of German and English key words 3–29
4	General system parameters 4–1
5	Speeds 5–1
5.1	Notes on the speed parameters 5–25
5.1.1	Axis travel in PTP (Point to point) 5–25
5.1.2	Axis travel in path operation (LINEAR, CIRCULAR) 5–26
5.1.3	Manual travel of the axes in WC 5–26
5.1.4	Manual travel of the axes in JC 5–27
5.1.5	Acceleration/deceleration change times PTP 5–28

Contents

6	Positions	6-1
7	Kinematic parameters	7-1
8	Measuring system parameters	8-1
8.1	P401 Equipment of the measuring system boards	8-1
8.2	P402 Direction of reference point travel	8-15
8.3	P403 Effectiveness of reference point switch	8-16
8.4	P404 Number of analog outputs	8-17
8.5	P405 Assignment of analog outputs	8-17
8.6	P406 Number of analog inputs	8-21
8.7	P407 Assignment of the analog input channels	8-21
9	Belt parameters	9-1
10	Drive parameters Servodyn-GC	10-1
10.1	Servodyn-GC-Parameter list	10-11
11	Drive parameters Servodyn-D	11-1
11.1	Servodyn-D - Parameter list	11-19
12	Table of parameters	12-1
A	Appendix	A-1
A.1	Abbreviations	A-1
A.2	Index	A-2

Safety Instructions

1 Safety Instructions

Please read this manual before you startup the rho4.
Store this manual in a place to which all users have access at any time.

1.1 Intended use

This instruction manual presents a comprehensive set of instructions and information required for the standard operation of the described products. The described products are used for the purpose of operating with a robot control rho4.

The products described

- have been developed, manufactured, tested and documented in compliance with the safety standards. These products normally pose no danger to persons or property if they are used in accordance with the handling stipulations and safety notes prescribed for their configuration, mounting, and proper operation.
- comply with the requirements of
 - the EMC Directives (89/336/EEC, 93/68/EEC and 93/44/EEC)
 - the Low-Voltage Directive (73/23/EEC)
 - the harmonized standards EN 50081-2 and EN 50082-2
- are designed for operation in industrial environments, i.e.
 - no direct connection to public low-voltage power supply,
 - connection to the medium- or high-voltage system via a transformer.

The following applies for application within a personal residence, in business areas, on retail premises or in a small-industry setting:

- Installation in a control cabinet or housing with high shield attenuation.
- Cables that exit the screened area must be provided with filtering or screening measures.
- The user will be required to obtain a single operating license issued by the appropriate national authority or approval body. In Germany, this is the Federal Institute for Posts and Telecommunications, and/or its local branch offices.

 **This is a Class A device. In a residential area, this device may cause radio interference. In such case, the user may be required to introduce suitable countermeasures, and to bear the cost of the same.**

The faultless, safe functioning of the product requires proper transport, storage, erection and installation as well as careful operation.

Safety Instructions

1.2 Qualified personnel

The requirements as to qualified personnel depend on the qualification profiles described by ZVEI (central association of the electrical industry) and VDMA (association of German machine and plant builders) in:

Weiterbildung in der Automatisierungstechnik

edited by: ZVEI and VDMA

MaschinenbauVerlag

Postfach 71 08 64

D-60498 Frankfurt.

The present manual is designed for RC technicians. They need special knowledge on handling and programming robots.

Interventions in the hardware and software of our products, unless described otherwise in this manual, are reserved to specialized Rexroth personnel.

Tampering with the hardware or software, ignoring warning signs attached to the components, or non-compliance with the warning notes given in this manual may result in serious bodily injury or damage to property.

Only electrotechnicians as recognized under IEC 60947-1 (modified) who are familiar with the contents of this manual may install and service the products described.

Such personnel are

- those who, being well trained and experienced in their field and familiar with the relevant norms, are able to analyze the jobs being carried out and recognize any hazards which may have arisen.
- those who have acquired the same amount of expert knowledge through years of experience that would normally be acquired through formal technical training.

With regard to the foregoing, please note our comprehensive range of training courses. Please visit our website at

<http://www.boschrexroth.com>

for the latest information concerning training courses, teachware and training systems. Personal information is available from our Didactic Center Erbach,

Telephone: (+49) (0) 60 62 78-600.

Safety Instructions

1.3 Safety markings on products

Warning of dangerous electrical voltage!



Warning of danger caused by batteries!



Electrostatically sensitive components!



Warning of hazardous light emissions
(optical fiber cable emissions)!



Disconnect mains power before opening!



Lug for connecting PE conductor only!



Functional earthing or low-noise earth only!



Connection of shield conductor only

Safety Instructions

1.4 Safety instructions in this manual



DANGEROUS ELECTRICAL VOLTAGE

This symbol is used to warn of a **dangerous electrical voltage**. The failure to observe the instructions in this manual in whole or in part may result in **personal injury**.



DANGER

This symbol is used wherever insufficient or lacking compliance with instructions may result in **personal injury**.



CAUTION

This symbol is used wherever insufficient or lacking compliance with instructions may result in **damage to equipment or data files**.

☞ This symbol is used to draw the user's attention to special circumstances.

★ This symbol is used if user activities are required.

Safety Instructions

1.5 Safety instructions for the described product**DANGER**

Danger of life through inadequate EMERGENCY-STOP devices! EMERGENCY-STOP devices must be active and within reach in all system modes. Releasing an EMERGENCY-STOP device must not result in an uncontrolled restart of the system! First check the EMERGENCY-STOP circuit, then switch the system on!

**DANGER**

**Danger for persons and equipment!
Test every new program before starting up a system!**

**DANGER**

**Retrofits or modifications may adversely affect the safety of the products described!
The consequences may include severe injury, damage to equipment, or environmental hazards. Possible retrofits or modifications to the system using third-party equipment therefore have to be approved by Rexroth.**

**DANGER**

Do not look directly into the LEDs in the optical fiber connection. Due to their high output, this may result in eye injuries. When the inverter is switched on, do not look into the LED or the open end of a short connected lead.

**DANGEROUS ELECTRICAL VOLTAGE**

Unless described otherwise, maintenance works must be performed on inactive systems! The system must be protected against unauthorized or accidental reclosing.

Measuring or test activities on the live system are reserved to qualified electrical personnel!

Safety Instructions



CAUTION

Danger to the module!

Do not insert or remove the module while the controller is switched ON! This may destroy the module. Prior to inserting or removing the module, switch OFF or remove the power supply module of the controller, external power supply and signal voltage!



CAUTION

use only spare parts approved by Rexroth!



CAUTION

Danger to the module!

All ESD protection measures must be observed when using the module! Prevent electrostatic discharges!

The following protective measures must be observed for modules and components sensitive to electrostatic discharge (ESD)!

- Personnel responsible for storage, transport, and handling must have training in ESD protection.
- ESD-sensitive components must be stored and transported in the prescribed protective packaging.
- ESD-sensitive components may only be handled at special ESD-workplaces.
- Personnel, working surfaces, as well as all equipment and tools which may come into contact with ESD-sensitive components must have the same potential (e.g. by grounding).
- Wear an approved grounding bracelet. The grounding bracelet must be connected with the working surface through a cable with an integrated 1 MΩ resistor.
- ESD-sensitive components may by no means come into contact with chargeable objects, including most plastic materials.
- When ESD-sensitive components are installed in or removed from equipment, the equipment must be de-energized.

Safety Instructions

1.6 Documentation, software release and trademarks

Documentation

The present manual provides information about settings of the rho4 machine parameters.

Overview of available documentation	Part no.	
	German	English
Rho 4.0 Connectivity Manual	1070 072 364	1070 072 365
Rho 4.0 System description	1070 072 366	1070 072 367
Rho 4.1/IPC 40.2 Connectivity Manual	R911308219	R911308220
Rho 4.1/BT155, Rho 4.1/BT155T, Rho 4.1/BT205 Connectivity manual	1070 072 362	1070 072 363
Rho 4.1, Rho 4.1/IPC300 Connectivity manual	1070 072 360	1070 072 361
Control panels BF2xxT/BF3xxT, connection	1070 073 814	1070 073 824
Rho 4.1 System description	1070 072 434	1070 072 185
ROPS4/Online	1070 072 423	1070 072 180
BAPS plus	1070 072 422	1070 072 187
BAPS3 Short description	1070 072 412	1070 072 177
BAPS3 Programming manual	1070 072 413	1070 072 178
Control functions	1070 072 420	1070 072 179
Signal descriptions	1070 072 415	1070 072 182
Status messages and warnings	1070 072 417	1070 072 181
Machine parameters	1070 072 414	1070 072 175
PHG2000	1070 072 421	1070 072 183
DDE-Server 4	1070 072 433	1070 072 184
DLL-Library	1070 072 418	1070 072 176
Rho 4 available documentation on CD ROM	1070 086 145	1070 086 145

 **In this manual the floppy disk drive always uses drive letter A:, and the hard disk drive always uses drive letter C:.**

Special keys or key combinations are shown enclosed in pointed brackets:

- Named keys: e.g., <Enter>, <PgUp>,
- Key combinations (pressed simultaneously): e.g., <Ctrl> + <PgUp>

Safety Instructions

Release

 **This manual refers to the following versions:**

Hardware version: rho4

Software release: ROPS4

Trademarks

All trademarks of software installed on Rexroth products upon delivery are the property of the respective manufacturer.

Upon delivery, all installed software is copyright-protected. The software may only be reproduced with the approval of Rexroth or in accordance with the license agreement of the respective manufacturer.

MS-DOS® and Windows™ are registered trademarks of Microsoft Corporation.

PROFIBUS® is a registered trademark of the PROFIBUS Nutzerorganisation e.V. (user organization).

MOBY® is a registered trademark of Siemens AG.

AS-I® is a registered trademark of AS-International Association.

SERCOS interface™ is a registered trademark of Interessengemeinschaft SERCOS interface e.V. (Joint VDW/ZVEI Working Committee).

INTERBUS-S® is a registered trade mark of Phoenix Contact.

DeviceNet® is a registered trade mark (TM) of ODVA (Open DeviceNet Vendor Association, Inc.).

General information

2 General information

The machine parameter program (MPP)

The operating system of the rho4 contains a program for reading system-specific data. These data are set by the service engineer when the installation is commissioned and are characteristic for the installation in question. Each change must be carefully considered and must be implemented only after consultation with the installation supplier.

Machine parameter groups

The machine parameters of the rho4 are divided into the following groups

- 0: General system parameters
- 100: Speeds, acceleration
- 200: Positions, software limit switches
- 300: Kinematic-related parameters
- 400: Measuring system configuration, reference point parameters and analog I/O
- 500: Belt parameters
- 600: Servodyn-GC parameters
- 700: Servodyn-D parameters

General information

Notes:

Application of the machine parameters

3 Application of the machine parameters

Using the machine parameters is possible in the following ways:

- Application via the PHG2000.
- Application via the machine parameter converter.

3.1 Application via the PHG2000

The machine parameters can be displayed and edited with the PHG2000 in in the operating mode Automatic and Setup.

- ★ By actuating <Mode> and <7>, the selection of the sub-mode Diagnosis is performed.
- ★ When <Mode> and <8> are actuated again, the sub-mode Machine parameters is selected.
- ★ When <Mode> is actuated again followed by <1> or <2>, the display or the setting function of the machine parameters is activated.

The following picture shows the key assignment of the PHG2000.

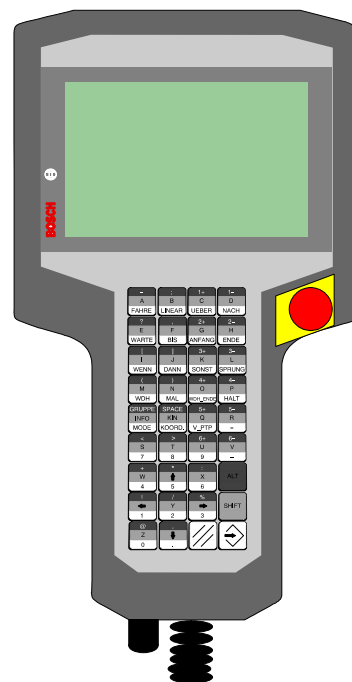

Application of the machine parameters

3.1.1 Input via the PHG2000

With the PHG2000, the user cannot only display machine parameters in the operating mode Diagnosis, but he can also change them. However, the change of machine parameters must meet several conditions:

- The robot must be at standstill for safety reasons. As criterion for that, the Emergency Stop signal is set.
- The valid password must be entered.
- All machine parameters can be displayed.
- The parameter selection is performed either by selecting the parameter group 0, 100, 200, 300, 400, 500, 600, 700 or directly by entering the parameter number.

 **The parameters of the group 600 and 700 are only accessible if in P401 at least 1 CAN axis with the corresponding drive type is entered.**

- Paging in the parameter groups is possible with the keys



- With



editing of the corresponding parameter is selected.

- If a parameter contains several items of information, it is possible to page through them by pressing



- Before a machine parameter can be changed, the correct password must be entered, see point 3.1.3.
- By simultaneously actuating the keys



the machine parameter program is left.

- If a parameter was selected previously, the inquiry appears, when leaving the menu 'Set machine parameters', whether the changed parameters should be stored. Entering 1 stores the new parameters and causes a new start-up of the control. If 0 is entered the changes are not saved and you return to the machine parameter menu.

Application of the machine parameters

3.1.2 Changing machine parameters with the PHG2000

- ★ For changing machine parameters, the following steps must be carried out

- 1 Press Emergency Stop
- 2 Select mode Diagnosis with <Mode> and <7>
- 3 Select machine parameters with <Mode> and <8>
- 4 Select mode 'Set machine parameters' with <Mode> and <2>
- 5 The following display appears on the PHG

The display shows the text 'KIN_1' on the left and 'MP SET' on the right in the top line. The second line shows 'Parameter No: #'.

- 6 Enter number of the desired machine parameter. First, the password is inquired.
- 7 Enter minus sign
- 8 Enter password, press <Enter>. For each entered digit, * appears as echo in line 2. The default password is '00000'.
- 9 When the input is correct, the PHG display shows the following picture

The display shows the text 'KIN_1' on the left and 'MP SET' on the right in the top line. The second line shows 'MP000000000000'. The third line shows '?: #'.

In line 3, the 12-digit machine parameter identification number is displayed. In line 4 of the PHG2000, the text **?: #** now appears. Here, a new identification number with max. 12 digits can be entered. Admissible are the digits 0 to 9, all letters, '.' and '_'.

If <Enter> is pressed without identification number, the old identification number is preserved.

The display of the machine parameter identification number appears if under Diagnosis mode Set or Display machine parameters is selected for the first time. The identification number is not displayed again when changing between Set and Display.

Application of the machine parameters

- 10 Enter number of parameter to be set. The entered parameter is displayed with its old value. In line 4, the new value can be entered.

```
KIN_1      MP SET
P101 NOMINAL LAG
A01  66.000
#
```

- 11 For further editing of machine parameters, enter number of parameter to be set.

 **The machine parameters are enabled by a correctly entered password until the user leaves the menu Set machine parameters.**

- 12 By actuating the keys

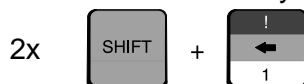

twice and simultaneously, the machine parameter program is left.

- 13 When leaving the menu 'Set machine parameters' you are prompted after a parameter change whether the changed parameters should be saved.

- 1 Save changed parameters; then a new run-up of the control is performed
- 0 Changed parameters are not adopted

Application of the machine parameters

3.1.3 Changing the password

- Changing the password is only possible in machine parameter enable condition, i.e. a valid password must have been entered.
- Input on the PHG2000: point 1 to 9 as under point 3.1.2 Changing machine parameters via the PHG2000.

 **The steps 1 to 9 may be omitted if a valid password has already been entered and the mode Set machine parameters is active.**

- 1 Instead of a parameter number, enter the character string === followed by <Enter>.
- 2 The text Address = # appears in line 2 of the PHG2000.
- 3 Enter the minus sign.
- 4 Enter the new, five-digit password. For each entered digit, * appears as echo in line 2.
- 5 When having terminated the input by <Enter>, the character string ***** appears in line 4 of the PHG2000 in order to acknowledge the change.
- 6 Leave the menu 'Set machine parameters' by entering twice

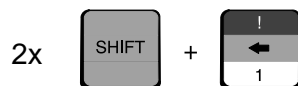

or change parameter by input of a parameter number.

 **In the operating system of the rho4, the password 00000 is predefined. It remains valid until the input of a new password. In the event of an EEPROM backup, the predefined password is active again.**

Application of the machine parameters

3.2 Kinematic selection in the machine parameter program

- All parameter groups with the exception of group 0, general system parameters, contain kinematic-specific parameters. The kinematic selected in the machine parameter program (MPP) appears on the PHG display in the first line top left. This display only appears if the selected parameter contains kinematic-specific values.

```
KIN_1      MP SET
P101 <IN POS> RANGE
A01  4.000
#
```

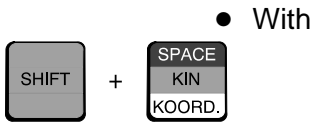

the kinematic can be changed over.

```
KIN_2      MP SET
P101 <IN POS> RANGE
B01  6.000
#
```

 **The first kinematic is always selected when the machine parameter program is called.**

Application of the machine parameters

3.3 Machine parameter converters

Machine parameter converters are PC tools by the help of which machine parameter sets of a rho4 can be changed into readable ASCII files and vice-versa.

The converters consist of two exe-files and two libraries which can be executed under Windows95 and WindowsNT. The Library MpParser.dll contains internal functions for changing ASCII lines into binary structures and vice-versa, while MpResD.dll (German) and MpResE.dll (English) contain language-dependent key words and texts. To be able to use functions from MpParser.dll, the files rmp.h and rimp.h must be included and the library mpparser.lib must also be linked.

The two machine parameter converters are components of ROPS4/Online and can there be called under the menu point 'Create'; they can, however, also be called in the DOS window of Windows resp. via Start/Execute.

3.3.1 Working principle

The converter MP to ASCII generates a readable ASCII file from a machine parameter file with the extension .bin. This ASCII file can be changed with each ASCII editor and adapted to the respective conditions.

In the ASCII file created by the converter MP to ASCII, the parameters are not sorted by parameter numbers, but in the first order by kinematics and then by axes.

The converter ASCII to MP changes an ASCII file with the extension .amp into a machine parameter file which can be loaded into the control or creates an extended machine parameter file for digital interfaces (see section 3.3.4 XMP converter). The distinction of which machine parameters are created is made by means of the extension of the ASCII file. If the converter is called with an AMP file, a BIN file (machine parameter file) is created. If it is called with an ISC file, an extended machine parameter file (file extension BSC) is created.

The ASCII file does not have to contain the complete machine parameter set. If the file MpDateiname.bin already exists when calling the converter ASCII to MP, only those parameters are converted in the machine parameter file which are also available in the ASCII file. All other parameters remain unchanged. The ASCII file can be created resp. edited with any ASCII editor.

If the file MpDateiname.bin does not exist at the moment of the call, all missing parameters are preset by standard values.

Application of the machine parameters

Call of the converter BIN to ASCII

Syntax:

MP_BIN_TO_ASCII [BIN-file [,AMP-file][,INI-file]]

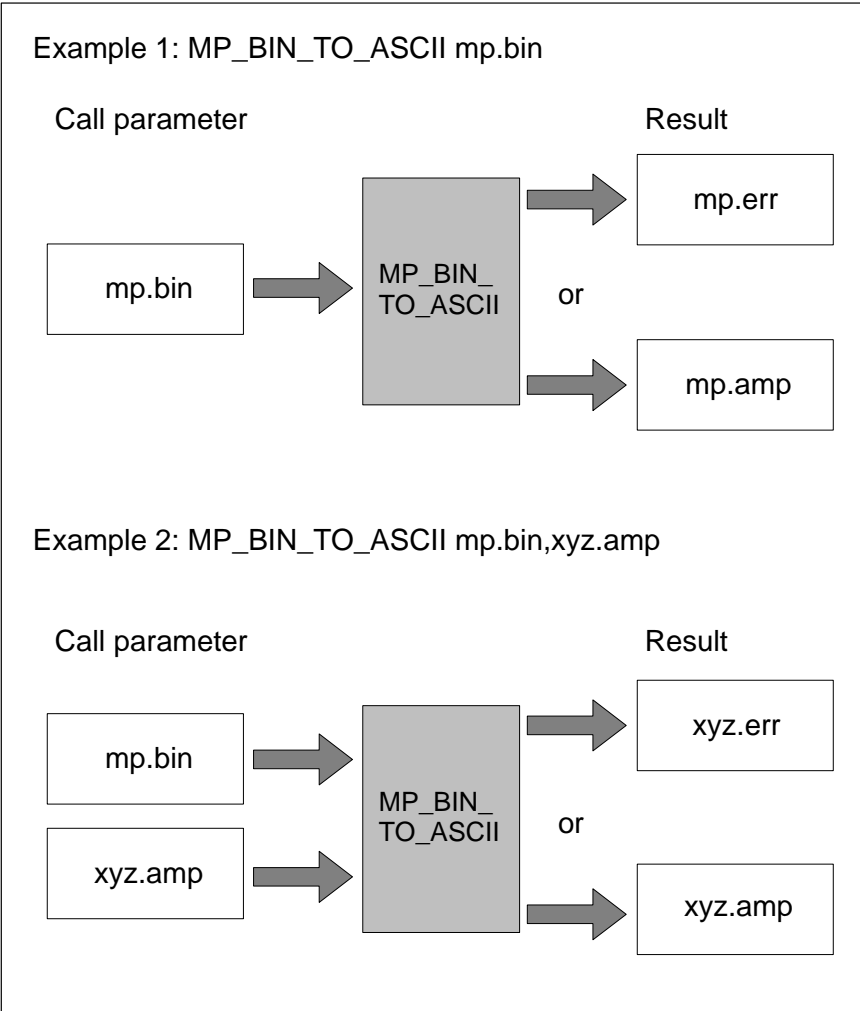

- BIN-file: Name (with indication of path of the BIN-file (machine parameters))
- AMP-file: Name of the ASCII-file with extension “AMP” (output file of the converter). The indication of the file name is optional. If it is not given (see example 1), an ASCII file with the same name is created as the machine parameter file with the extension “AMP”. The extension “AMP” refers to an **A**SCII **M**achine **P**arameter file. If the file name is given without a path, it will be the path of the BIN file.
- INI-file: Name of an INI-file (see section 3.3.3 Initialization file MPKONV.INI). The indication of the file name is also optional and can be selected to make specific settings for the conversion. The file name must have the extension “INI”. If the file name is given without a path, it will be the path of the BIN file. If it is missign, the INI file from the directory of the converter will be used.

Application of the machine parameters

Call of the converter ASCII to BIN

Syntax:

MP_ASCII_TO_BIN [AMP-file [,BIN-file][,INIfile]]

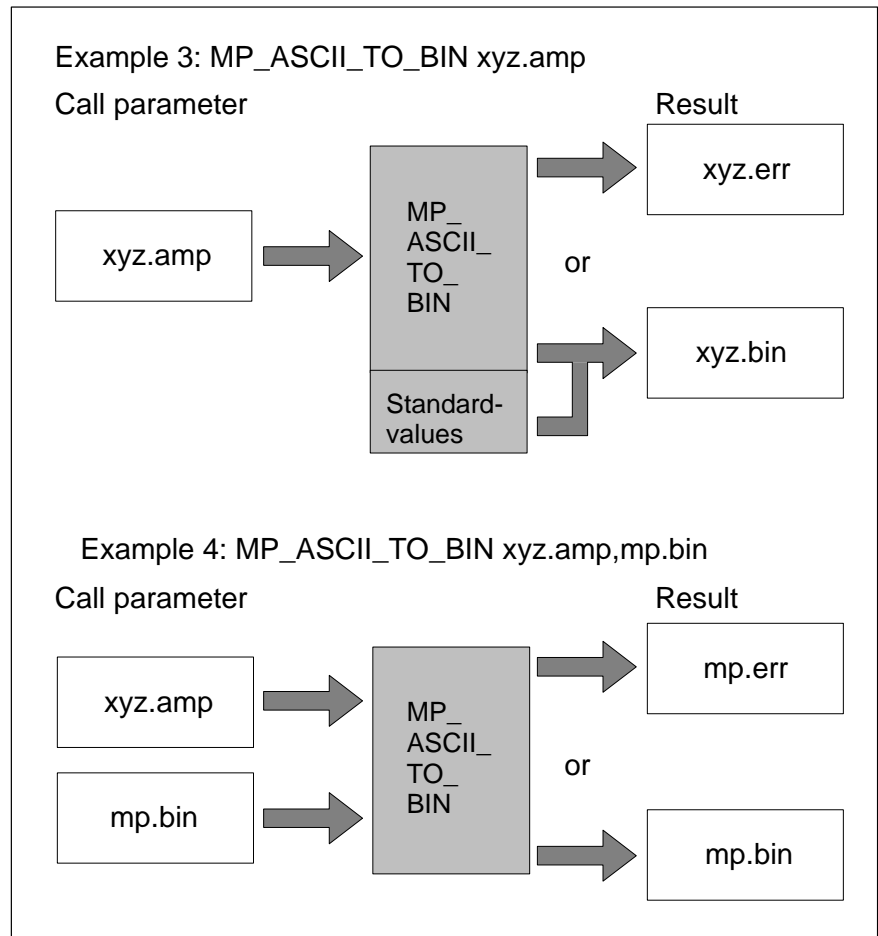

- AMP-file:** Name with indication of path of the AMP-file (ASCII-file, containing machine parameters). The extension "AMP" refers to an **A**SCII **M**achine **P**arameter file
- BIN-file:** Name of the BIN-file with extension "BIN" (output file of the converter). The indication of the file name is optional. If it is not given (see example 1), a BIN file with the same name is created as the machine parameter file with the extension "BIN". If the file name is given without a path, it will be the path of the AMP file.
- INI-file:** Name of an INI-file (see section 3.3.3 Initialization file MPKONV.INI). The indication of the file name is also optional and can be selected to make specific settings for the conversion. The file name must have the extension "INI". If the file name is given without a path, it will be the path of the AMP file. If it is missing, the INI file from the directory of the converter will be used.

Application of the machine parameters

- ✉ **Machine parameter sets of a rho3 control cannot be directly edited with converters. They must at first be loaded into a rho4. When loaded into a rho4, rho3 machine parameters are automatically reformatted and adapted to the new machine parameter format of the rho4. These changed parameters can then be edited with the converters.**

3.3.2 Syntax of the ASCII file

The ASCII file is automatically created by the call of the converter MP to ASCII. It can also be created by manual input via a commercial ASCII editor. When changing and creating an ASCII file, several syntactical rules have to be observed for the input of the individual parameters. They are described in the following sections by giving examples:

- Key words, i. e. the name identifier of the individual parameter, can be entered in German or English. Within an ASCII file, a language mixture is not permitted.
- P and the parameter number are entered before each key word, separated by a point.
- Capital letters/small letters only serve the better legibility and are not distinguished by the converter.
- Comments are characterized by a preceding semicolon ';' and are overread by the converter.
- The maximum length of a line is 255 characters, including CR and LF at the end of the line.
- A line is terminated by CR and LF.
- Pre and post comma positions of decimal numbers can be separated by "." or ",".
- In case of an input of new machine parameter values into the ASCII file, a minimum value range control is carried out. When these ranges are exceeded, a warning is entered in the error file. The value in the BIN file is kept or is replaced by the standard value.

Application of the machine parameters

3.3.3 Initialization file MPKONV.ini

The file MPKONV.ini serves the two MP converters for initialization and presetting of specific characteristics and for storing the actual working directory. The entries can be performed with each ASCII editor. The values indicated in the following list are default values.

[MPKONV]

```
WorkingDir=c:\Bosch\  
LastDir=C:\  
//Language=deutsch  
Language=english  
Deutsch=MPRESD.DLL  
English=MPRESE.DLL  
LIMITCHECK=1  
VIEWSTATUS=1  
AUSDRUCK=KIN  
CHECKBINFILE=1
```

Section	Description	
[MPKONV]	It is not allowed to change the section name (MPKONV)	
	Entry	Meaning
	WorkingDir	Is only used internally and should not be changed
	LastDir	Last directory from which a file has been selected for the converter
	Language	Language version for the key words of the converter- deutsch = German key words and German comments of an amp-file created per converter english = English key words and English comments of an amp-file created per converter
	Deutsch	Name of the dll for the German version (must not be changed)
	English	Name of the dll for the English version (must not be changed)
	LimitCheck	The converter MP_ASCII_TO_BIN checks the read-in MP values for validity (value range) 0 = check not active 1 = check active (recommended!)
	ViewStatus	0 = the status window is not displayed at the end of a conversion process 1 = the status window is displayed at the end of a con version process
	Ausdruck	KIN = The parameters in the amp file created by the converter are sorted according to kinematic PARA = the parameters in the amp-file created by the converter are sorted according to parameter numbers

Application of the machine parameters

Section	Description	
[MPKONV]	CheckBinFile	<p>1 = During the conversion BIN→ASCII a check for valid parameter values is performed. If the values are beyond the validity area (possible for parameters that have not yet been required) the corresponding line in the amp file is marked as comment.</p> <p>0 = During the conversion BIN→AMP a check for valid parameter values is performed. The converter writes all known parameters into the amp file (also those which have not yet been used or assigned). This may result in the display of error messages (invalid parameter value) when a conversion from ASCII→BIN follows (without the parameters not needed being removed before).</p>

3.3.4 XMP converter

Sercos interface and CANopen are realized as digital interfaces in the rho4 control unit. Axes (Sercos), belts (Sercos & CANopen), transmitter (CANopen) and decentral digital or analog I/Os (CANopen) can be controlled via these ones. The corresponding machine parameters are the Extended Machine Parameters (XMP).

All the Extended Machine Parameters are saved in the control unit in a special file. These parameters are transferred only in the initialization phase per download to the peripheral unit; they are otherwise not required in the control unit.

An ASCII-file created with the Bosch-DSS program serves as a basis. The program DSS (**D**iagnosis and **S**ervice **S**ystem) is used e.g. as a help for start-up and diagnosis tool for the drive converter Servodyn-D.

After completed optimization, an ASCII file which contains all parameters of a special peripheral unit (axis, belt, I/O module) can be created per DSS. This is to be carried out for all peripheral units.

These ASCII files are to be filed in a PC directory which can be selected freely under the following fixed name:

```
Axis1.scs
Axis2.scs
.
.
Axisn.scs
```

In Sercos axes, the file name number corresponds to the consecutive axis numbering.

Application of the machine parameters

In CANopen-Axes, belts, transmitters and decentral I/Os, the file name number corresponds to the DSS index indicated under machine parameter P401, i.e. belts, transmitters and decentral I/Os are filed also under the name **Axism.scs**.

Preceding zeros are allowed in the file name number, capital/small letters are not distinguished, e.g. AXIS003.scs.

In a further ASCII file, the peripheral units, for which there is a parameter download, are grouped. This file is named in the following Include file. The name of the Include file can be freely selected, the extension must be '.isc', e.g:

Scara1.isc

The extended machine parameter converter (XMP converter) is a tool generating a binary file for the rho4 control unit from an isc-ASCII file. It is an extension of the machine parameter converter. It changes the ASCII files listed in the isc file into an extended machine parameter file.

Calling the XMP converter Ascii to BIN

- The XMP converter is part of ROPS4 and can be called there in the menu of "ONLINE" under 'Create' → 'ASCII to MP' → 'XMP-Ascii → BSC'.
- The XMP converter can also be activated under MS-DOS with a command line.

Syntax:

```
MP_ASCII_TO_BIN [Asciifilename.ISC [","XMPFilename.BSC][","INI-file]]
```

Application of the machine parameters

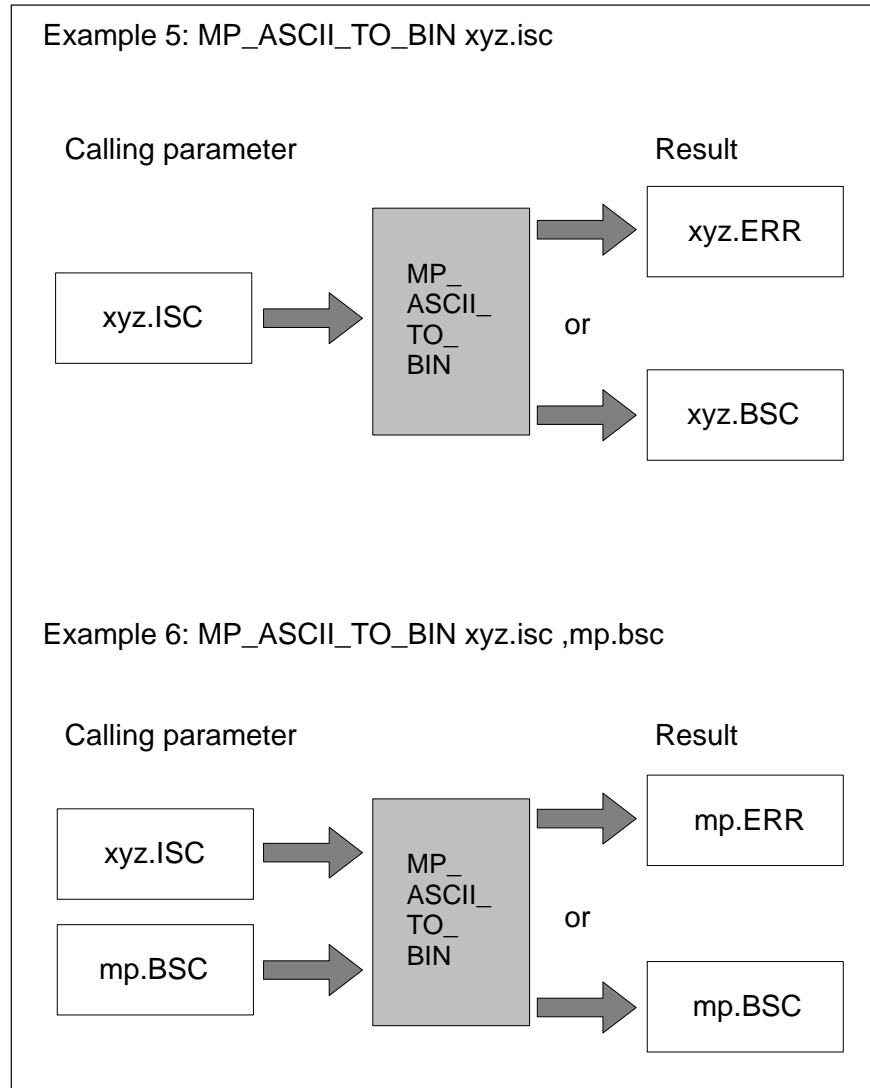

“Asciifilename.ISC” is the name (with path) of the ASCII-Include file. The extension “.ISC” must be indicated.

“XMpFilename.BSC” is the name of the extended machine parameter file. It is optional to indicate the XMpfilename. If it is not indicated, a machine parameter file with the same name as the ASCII file is created with the ending “BSC”. If the file name is indicated without a path, the path of the ISC file is adopted.

“INI file” is the name of an INI file (see section 3.3.3 Initialization file MPKONV.INI). This is also an option and can be chosen to make specific adjustments for the conversion. The file name must have the ending “INI”. If the file name is indicated without a path, the path of the ISC file is adopted. If this indication is omitted, the INI-file from the directory of the converter is used.

Application of the machine parameters

Possible conversion errors are documented in the file "XMpFilename.ERR" or "Asciifilename.ERR", depending on which calling parameters are indicated. In exception cases, when e.g. no file name can give or the converter can find the necessary DLLs, the error file "MP_ASCII_TO_BIN.ERR" contains the error message. This file is in the same path as the converter "MP_ASCII_TO_BIN".

The binary file '*.BSC' created in this way can be loaded into the rho4 control unit per Rops4 coupling. When the control unit is shut down, the extended machine parameters are saved in the directory c:\Bosch\rho\kpc under the name ~dfxmp_.bin and are available when the control unit is started.

Syntax of the Include file

In the Include file, all scs files are listed for which a parameter download is carried out. The scs files including drive and path must be indicated. The file name itself is fixed; it must be

Axisn.scs

where the numbers from 1 to 64 are allowed for n. Preceding zeros are allowed, blanks ignored, empty lines and comments are allowed. A comment always begins with a semicolon ';'.
';

Example for an Include file:

```
;-----
;This is an example for an isc-Include file
;-----

c:\scara1\xmp\axis001.scs    ;Axis 1
                             ;no parameter for
                             ;Axis 2

c:\scara1\xmp\axis03.scs    ;Axis 3

c:\scara1\xmp\axis4.scs     ;Axis 4

c:\scara1\xmp\axis5.scs     ;Belt 1
```

Application of the machine parameters

Syntax of the Scs-ASCII file

A Scs-ASCII file contains all parameters of a special peripheral unit (axis, belt, I/O module) that are transmitted when the control unit is started. The Scs file does not need to be created with the DSS, but the syntax described in the DSS manual is to be observed. The Scs file can be edited with any Ascii editor.

Every line begins with a key word, followed by an equals sign and following value assignment (service date). Allowed key words are 'Axis', 'Phase' and all ident number, e.g (see also example 1 in section 3.3.1 Functional principle):

```
IdentNo = Value ;Assignment of individual value
IdentNo = Value1, Value2, ..., Valuen ;List assignment
```

The line with the key word 'Axis' is ignored as comment line, since the axis number is coded via the file name.

The key word 'Phase' indicates that the parameters listed below are transmitted in the corresponding start phase to the peripheral unit, e.g. 'Phase = 2'). In the Scs-ASCII file, the parameters of the initialization phase 2 must be first listed and then the ones of the phase 3.

The syntax of the ident numbers depends on whether the corresponding peripheral unit is controlled per Sercos or per CANopen interface.

SERCOS-Ident number

For SERCOS ident numbers the following structure is defined:

```
[S-/P-][Parameter set-][0..4095]
```

```
S    Standard ident number
P    product specific ident number
```

The parameter set must only be indicated if it is different from zero. The following syntaxes are allowed for standard ident numbers:

```
1
S1
S-1
S-0-1
S-0-0001
```

For product specific ident numbers, the following syntaxes are allowed:

```
P1
P-1
P-0-1
P-0-0001
```

CANopen Ident numbers

For CANopen parameters the following syntax applies:

Application of the machine parameters

C[-]index[.subindex]

The prefix 'C' has to be written in every case. The subindex must only be indicated if it is different from zero. The following syntaxes are allowed:

C1400
C1400.0
C-1400
C-1400.0

Data formats operational date

The operational data can be indicated in different formats. They are defined through a corresponding prefix:

Prefix	Signification	Example
	Date as integer value	125
	Datum as decimal value, The decimal point '.' must be set	125.0
0x	Date as hexadecimal value	0xffff
0b	Date as binary value	0b00001111
S	Date as standard ident number	S-0051
P	Date as product specific ident number	P-0480
C	Date as CANopen ident number	C-1400

Besides individual values, operational date lists can be assigned. Lists require to bracket list elements. The elements are separated through a comma, empty lists are allowed, e.g.:

(S-36, S-45, S-100)
()

The Sercos parameters S-0-0141, S-0-0142, S-0-0267 and S-0-0432 have a special place. Their operational date consists of a list of Ascii signs, i.e. the operational date is a text string. Brackets and commas in the string are forbidden, blanks and tabulators are ignored, e.g:

S-0-0142 = (lamAxis-5)

Application of the machine parameters

Example 1 (SERCOS parameter):

;-----	Semicolon characterizes comment
AXIS = 3	; is interpreted as comment!!!
PHASE = 2	; Phase conversion
S-0-0032= 0b0000.0000.0000.0010	; Standard Par. Ident No. 32 binary
S-0-0089= 1000	; Standard Par. Ident No. 89 Integer
S-0-0123= 1.000	; Standard Par. Ident No. 123 decimal
S-0-0016= (S-0-0051,S-0-0189,S-0-0-0040)	; Configuration list drive telegram
S-0-0026= ()	; Empty configuration list Signal Status word
S-0-0142= (Achse-3)	; Axis recognition as Text string
P-2-0004= 0x12af	; product spec. Ident No. 4 hexadec. H'12af
P-0-0121= (1000.0,1000.0))	; product spec. Ident No. 121 decimal list

Application of the machine parameters

3.3.5 Dependences

Several machine parameters are interdependent to some extent. This means that when changing one parameter, one or several other parameters must be adapted. If e.g. the number of axes is increased in parameter P302, parameters P401 must also be adapted.

The following table indicates the parameter dependences.

Changed parameter	Parameters that must be adapted
P1.Number of kinematics	P401 (Observe dependences on P401) P301 P306 (Observe dependences on P306)
P30.Number of outputs.CANBUS	P32
P30.Number of inputs.CANBUS	P31
P214.PassingCrit	P213
P302.Axis number.Kin	P101, P103, P104, P105, P107 to P114, P117, P122, P123, P125 to P130 P201 to P208, P213 P303, P304, P305, P311 P401 (Observe dependences on P401) P402, P403 P601 to P615 (With Servodyn-G) P701 to P737 (With Servodyn-D)
P303.AxisType.Kin.Axis	If P303.AxisType.Kin.Axis = 3 (Endless axis) is set, the following parameters must be adapted: P311 and P306.EndlessAxesHB.Kin
P306.RobotType.Kin	P301, P307 to P310, P313 P302 (Observe dependences on P302) P501 (Observe dependences on P501)
P401.SlotNumber.Kin.Axis	If P401.SlotNumber.Kin.Axis is set to X51 or X52, the following values must be set in dependence on P401.CANDriveMode.Kin.Axis: If P401.CANDriveMode.Kin.Axis = 0 is set, P601 to P615 must be entered. If P401.CANDriveMode.Kin.Axis = 1 is set, P701 to P745 must be entered.
P402.RefPointDirection.Kin.Axis	P403 P207, P208
P501.Belt number	P503 to P508 P401

Application of the machine parameters

 **When converting an ASCII file (.amp) into a machine parameter set (.bin), a notice is given in the error file (.err) about possible dependences on the programmed parameters. If for instance, the parameter P214.PassingCrit. is set, and the parameter P213.PassingDistance.Kin.Axis is not set, a corresponding warning appears in the error file. The machine parameter file (.bin) is nevertheless created. The missing value for P213 then remains occupied by the standard value.**

3.3.6 Example for first creation of an ASCII file

In a machine parameter set, the number of kinematics is to be increased from 1 to 2.

The basis for the first creation of an ASCII file is the machine parameter set with standard parameters described in this manual.

These standard parameters are entered in the event of a machine parameter backup of the control. Of course, every other machine parameter set can serve as basis.

A kinematic with 2 axes is preset. A standard ASCII file can be created by the converter MP to ASCII. There, all kinematic and axis dependent parameters refer to a kinematic with 2 axis. Missing entries for a 2nd kinematic for instance or for further axes must be edited.

In order to avoid unnecessary work with typing, the following procedure is recommended:

- Set the number of kinematics (P1KinematicsNumb.) and number of axes (P302AxisNumber.Kinx) to the desired number in the standard ASCII file described above.
- Convert the ASCII file with the new number of kinematics and number of axes (ASCII to MP).
- Reconvert the so created bin-file into an ASCII file (MP to ASCII). All kinematic and axis dependent parameters are now included in the ASCII file and can be adapted to the respective machine.

The same procedure is recommended for the selection of belts, analog inputs/outputs or similar parameters which require the setting of additional parameters.

Application of the machine parameters

3.3.7 Standard values and key words of the machine parameter converters

When during the call of ASCII to MP the destination file MpFilename.bin is not indicated, it is given the same name as the ASCII file, only with the extension '.bin'. If this bin-file is not available, it is created and preset with standard values. The standard values are the same values which are set in a machine parameter backup in the rho4. When the ASCII file is then converted, the entries which are available there, are adopted. All entries missing in the ASCII file are occupied with the standard values.

The values indicated in the column Parameter index are parameter indices for the call of the functions in the library MpParser.dll.

;x = 1.. Number of kinematics

;y = 1.. Axis number of the corresponding kinematic

;z = 1.. Coordinate of the corresponding kinematic

;b = 1.. Belt number of the corresponding kinematic

Parameter number	Designation	Presettings	Parameter index
0	MPIidentification	MP000000000000 0	0
1	KinNumber	1	100
2	Mach_Conf	0	200
4	InpParity	none	400
5	ClockStTime	10	500
6	RtimeMonPa ;a = 1 or 2	200	601 to 602
8	UserStOuta ;a = 401 to 416	110	800 to 815
9	SysStrobeOut	110	900
10	SelLanguage	German	1000
11	ProbeNumber	0	1100
16	IRDATAStack	4.000	1600
19	PhgKeyGroups	5	1900
19	PHGKeyDispl	0	1901
20	IoHwConfig	0	2000
21	StartAddrPLC	0	2101
21	EndAddrPLC	255	2102
21	RTimeControlPLC	250	2103
21	InterbusS	0	2104
22	RangeAfaMin	0.0001	2200
22	RangeAfaMax	9.9999	2201
22	RangeDfaMin	0.0001	2202

Application of the machine parameters

Parameter number	Designation	Presettings	Parameter index
22	RangeDfaMax	9.9999	2203
23	RangeVfaMin	0.0001	2300
23	RangeVfaMax	9.9999	2301
24	DelUserOut	199	2400
25	AVDResetKIN	0	2500
25	AVDAutManKIN	0	2501
25	AVDManAutKIN	0	2502
25	AVDProSelKIN	0	2503
25	AVDResetGLO	0	2504
25	AVDAutManGLO	0	2505
25	AVDManAutGLO	0	2506
25	AVDProSelGLO	0	2507
27	StrIntegInp	0	2700
30	CANInpNumb	0	3000
30	CANOutNumb	0	3001
30	CANSRCNumb	0	3002
30	Baudrate.CANBUSa ;a = 1 to 3	0	3003
30	CANOpenDownLoad	0	3004
30	ProtocolType.CANBUSa ;a = 1 to 3	0	3005
31	CANInpStAdr.Blockc ;c = 1 to 40	0	3100
31	CANInpLeng.Blockc ;c = 1 to 40	0	3101
31	CANInpIdent.Blockc ;c = 1 to 40	0	3102
31	InputCANBUS.Blockc ;c = 1 to 40	0	3103
31	InputEAType.Blockc ;c = 1 bis 40	0	3104
31	InputDSSRef.Blockc ;c = 1 bis 40	0	3105
32	CANOutStAdr.Blockc ;c = 1 to 40	0	3200
32	CANOutLeng.Blockc ;c = 1 to 40	0	3201
32	CANOutIdent.Blockc ;c = 1 to 40	0	3202
32	OutputCANBUS.Blockc ;c = 1 to 40	0	3203
32	OutputEAArt.Blockc ;c = 1 to 40	0	3204
32	OutputDSSRef.Blockc ;c = 1 to 40	0	3205
34	Uart0Blocklena ;a = 1 to 4		3400
35	Phg3CompMode	0	3500
36	AddrMultiFuncInputs	-1	3600
36	AddrMultiFuncOutputs	-1	3601

Application of the machine parameters

Parameter number	Designation	Presettings	Parameter index
36	AddrMultiFunc2Inputs	-1	3602
36	AddrMultiFunc2Outputs	-1	3603
37	SRCANInIdent.Blockc	;c = 1 to 40, minus the I/O set under P30	3701
37	SRCANOutIdent.Blockc	;c = 1 to 40, minus the I/O set under P30	3702
37	SRCANBUSNum.Blockc	;c = 1 to 40, minus the I/O set under P30	3703
38	SERCOSBaudrate	2	3800
38	SERCOSDownload	0	3801
39	KinNo.Workspacee	;e = 0 to 32	3901
	Xmin.Workspacee	0.000	3902
	Xmax.Workspacee	0.000	3903
	Ymin.Workspacee	0.000	3904
	Ymax.Workspacee	0.000	3905
	Zmin.Workspacee	0.000	3906
	Zmax.Workspacee	0.000	3907
101	NomLag.Kinx.Axisy	66.00	10100
102	MaxPathSpeed.Kinx	1500.00	10200
103	MaxPtpSpeed.Kinx.Axisy	50.00	10300
104	AcclPtp.Kinx.Axisy	9999.00	10400
105	SloPointPtp.Kinx.Axisy	2000.00	10500
106	SlpPathBlock.Kinx	0.000	10600
106	SlpPathProg.Kinx	0.000	10601
107	SloPointWc.Kinx.Coordz	2000.00	10700
108	RefSpeed.Kinx.Axisy	10.00	10800
109	RefSpeed1Red.Kinx.Axisy	10.00	10900
110	RefSpeed2Red.Kinx.Axisy	4.00	11000
111	JogSpWcSlow.Kinx.Coordz	5.00	11100
112	JogSpWcFast.Kinx.Coordz	25.00	11200
113	JogSpJcSlow.Kinx.Axisy	3.00	11300
114	JogSpJcFast.Kinx.Axisy	15.00	11400
115	IncStWcSmall.Kinx	1.00	11500
115	IncStWcLarge.Kinx	10.00	11501
116	IncStJcSmall.Kinx	0.500	11600
116	IncStJcLarge.Kinx	5.00	11601

Application of the machine parameters

Parameter number	Designation	Presettings	Parameter index
117	ASlopeJogWc.Kinx.Coordz	1000.00	11700
117	DSlopeJogWc.Kinx.Coordz	1000.00	11701
118	RangeAfaMin.Kinx	0.0001	11800
118	RangeAfaMax.Kinx	9.9999	11801
118	RangeDfaMin.Kinx	0.0001	11802
118	RangeDfaMax.Kinx	9.9999	11803
119	RangeVfaMin.Kinx	0.0001	11900
119	RangeVfaMax.Kinx	3.3333	11901
120	SlopeMode.Kinx	0	12000
121	SlopeForm.Kinx	0	12100
122	ATimePtpJc.Kinx.Axisy	100.00	12200
122	DTimePtpJc.Kinx.Axisy	100.00	12201
123	ATimeJogWc.Kinx.Coordz	100.00	12300
123	DTimeJogWc.Kinx.Coordz	100.00	12301
124	ATimeJogPath.Kinx	100.00	12400
124	DTimeJogPath.Kinx	100.00	12401
125	SwOffTimeIpo.Kinx.Axisy	2000	12500
126	SwOffTimeSta.Kinx.Axisy	2000	12600
127	InPosStStill.Kinx.Axisy	10.00	12700
128	ASlopeJogJc.Kinx.Axisy	9999.0	12800
128	DSlopeJogJc.Kinx.Axisy	9999.0	12801
129	SloPointJog.Kinx.Axisy	2000.00	12900
130	ATimeJogJc.Kinx.Axisy	100	13000
130	DTimeJogJc.Kinx.Axisy	100.00	13001
201	InPosRange.Kinx.Axisy	4.00	20100
202	SwLimPosWc.Kinx.Coordz	9999.99	20200
203	SwLimNegWc.Kinx.Coordz	-9999.99	20300
204	SwLimPosJc.Kinx.Axisy	360.00	20400
205	SwLimNegJc.Kinx.Axisy	-360.00	20500
206	SwLimTol.Kinx.Axisy	1.500	20600
207	RefPoiPos.Kinx.Axisy	0.000	20700
208	RefPoiOff.Kinx.Axisy	0.000	20800
212	PassDisWc.Kinx	0.000	21200
212	PassDisJc.Kinx	0.000	21201
213	PassDist.Kinx.Axisy	0.000	21300

Application of the machine parameters

Parameter number	Designation	Presettings	Parameter index
214	PassCrit.Kinx	0	21400
301	KinName.Kinx	ROBI_1	30100
302	KinAxisNumb.Kinx	2	30200
303	Axis Type.Kinx.Axisy	0	30300
304	AxisName.Kinx.Axisy	A0y	30400
305	AxisCoord.Kinx.Coordz	K0y	30500
306	KinRobType.Kinx	0	30600
306	KinRefAllAx.Kinx	0	30601
306	KinIposCoord.Kinx	0	30602
306	KinIposComm.Kinx	0	30603
306	KinEndless.Kinx	0	30604
306	KinAxisConWc.Kinx	0	30605
307	KinAxisLeng.Kinx.Arma ;a = 1 to 8	1.00	30700
308	KinCoupFact.Kinx.Factora ;a = 1 to 8	0.000	30800
309	KinFlangeCooX.Kinx KinFlangeCooY.Kinx KinFlangeCooZ.Kinx KinFlangeCooO1.Kinx KinFlangeCooO2.Kinx KinFlangeCooO3.Kinx	0.000	30900 30901 30902 30903 30904 30905
310	KinWcCoorOffX.Kinx KinWcCoorOffY.Kinx KinWcCoorOffZ.Kinx KinWcCoorOffA.Kinx KinWcCoorOffB.Kinx KinWcCoorOffC.Kinx	0.000	31000 31001 31002 31003 31004 31005
311	ModValue.Kinx.Axisy	1.000	31100
313	KinWcSysAssgx.Kinx KinWcSysAssgy.Kinx KinWcSysAssgz.Kinx KinWcSysAssga.Kinx KinWcSysAssgb.Kinx KinWcSysAssgc.Kinx	0	31300 31301 31302 31303 31304 31305
314	Seriesnumber.Kinx	Basic initialization of the series number of the electro. type plates	31400
401	SbNum.Kinx.Axisy	1	40100
401	SbNum.Kinx.Beltb	1	40120
401	SlotNum.Kinx.Axisy	X99	40101

Application of the machine parameters

Parameter number	Designation	Presettings	Parameter index
401	SlotNum.Kinx.Beltb	X99	40121
401	ModulNum.Kinx.Axisy	1	40102
401	ModulNum.Kinx.Beltb	1	40122
401	IncMarkDis.Kinx.Axisy	1000	40103
401	INCMarkDis.Kinx.Beltb		40129
401	CANGearFac.Kinx.Axisy	0.000	40104
401	CANResPCount.Kinx.Axisy	8192	40105
401	CANResPCount.Kinx.Beltb		40136
401	CANModuloValue.Kinx.Axisy	0	40130
401	CANModuloValue.Kinx.Beltb		40131
401	CANDistancePerRevolution.Kinx.Axisy	0.1	40132
401	MeaSysFactor.Kinx.Axisy	1000.00	40106
401	MeaSysFactor.Kinx.Beltb	1000	40123
401	ComOutput.Kinx.Axisy	1	40107
401	CANModAxNum.Kinx.Axisy	0	40112
401	CANModAxNum.Kinx.Beltb		40133
401	CANDriveMode.Kinx.Axisy	0	40113
401	CANDriveMode.Kinx.Beltb		40134
401	CANPulseRate.Kinx.Axisy	0	40114
401	CANPulseRate.Kinx.Beltb		40135
401	CANRefMode.Kinx.Axisy	0	40115
401	CANOffset.Kinx.Axisy	0	40124
401	CANOffset.Kinx.Beltb		40137
401	CANDSSRef.Kinx.Axisy	0	40125
401	CANDSSRef.Kinx.Beltb		40138
401	CANNodeID.Kinx.Axisy	0	40147
401	CANNodeID.Kinx.Beltb		40148
401	SERCOSDriveMode.Kinx.Axisy	0	40126
401	SERCOSDriveMode.Kinx.Beltb		40139
401	SERCOSModAxNum.Kinx.Axisy	0	40140
401	SERCOSModAxNum.Kinx.Beltb		40141
401	SERCOSRefMode.Kinx.Axisy	0	40142
401	SERCOSGearFac.Kinx.Axisy	0	40143
401	SERCOSModuloValue.Kinx.Axisy	0	40144
401	SERCOSModuloValue.Kinx.Beltb		40145

Application of the machine parameters

Parameter number	Designation	Presettings	Parameter index
401	SERCOSDistancePerRevolution.Kinx.Axisy	0.1	40146
401	SERCOSSRing.Kinx.Axisy		40149
401	SERCOSSRing.Kinx.Beltb		40150
402	RefDir.Kinx.Axisy	0	40200
403	RefPoiSwt.Kinx.Axisy	0	40300
404	NumberAnalogOutputs	0	40400
405	AnalogOutAlloc.Outputa MAX_MS	;a = 1 to 0	40501
405	AnalogOutStartAddr.Outputa MAX_MS	;a = 1 to 0	40502
405	AnalogOutFormat.Outputa MAX_MS	;a = 1 to 0	40503
405	AnalogOutNominalValue.Outputa MAX_MS	;a = 1 to 0	40504
405	AnalogOutVoltageOffset.Outputa MAX_MS	;a = 1 to 0	40505
406	NumberAnalogInput	0	40600
407	AnalogInAlloc.Inputa MAX_MS	;a = 1 to 0	40701
407	AnalogInStartAddr.Inputa MAX_MS	;a = 1 to 0	40702
407	AnalogInFormat.Inputa MAX_MS	;a = 1 to 0	40703
407	AnalogInNominalValue.Inputa MAX_MS	;a = 1 to 0	40704
501	KinBeltNumb.Kinx	0	50100
503	BeltDirCos.Kinx.Beltb.Coordz	0.000	50300
505	BeltCoLimMax.Kinx.Beltb	5000	50501
505	BeltCoLimMax.Kinx.Beltb	5000	50502
506	BeltName.Kinx.Beltb	B01	50600
507	BeltTimeOff.Kinx.Beltb	0.000	50700
508	BeltSimVel.Kinx.Beltb	0.000	50800
601	DIAntrPar	0	60100
602	ControllerId.Kinx.Axisy	1	60200
603	MotorId.Kinx.Axisy	0	60300
604	VelGain.Kinx.Axisy	0.000	60400
605	VelTi.Kinx.Axisy	0.000	60500
606	PropGain.Kinx.Axisy	0.000	60600

Application of the machine parameters

Parameter number	Designation	Presettings	Parameter index
607	AutoTorqueLi.Kinx.Axisy	0.00	60700
607	ManTorqueLi.Kinx.Axisy	0.00	60701
607	EmTorqueLi.Kinx.Axisy	0.00	60702
608	EmDecelerat.Kinx.Axisy	0.000	60800
609	EmBreakingV.Kinx.Axisy	0.000	60900
610	StaticErr.Kinx.Axisy	1024	61000
611	KevSi.Kinx.Axisy	400	61100
612	FnTorque.Kinx.Axisy	0.000	61200
613	ZTorque.Kinx.Axisy	0.000	61300
614	HomePosOff.Kinx.Axisy	0.000	61400
615	EnTempProt.Kinx.Axisy	0	61500
701	DIAntrPar	0	70100
702	PrimOpMode.Kinx.Axisy	3	70200
703	VelProp.Kinx.Axisy	50.00	70300
704	VelIntTim.Kinx.Axisy	10.00	70400
705	C1PropReg.Kinx.Axisy	1000.00	70500
706	C1IntTime.Kinx.Axisy	100000	70600
707	C2PropReg.Kinx.Axisy	1000.00	70700
708	C2IntTime.Kinx.Axisy	100000	70800
709	AmplWTemp.Kinx.Axisy	75.00	70900
710	MotoWTemp.Kinx.Axisy	145.00	71000
711	PowOutFrq.Kinx.Axisy	8000	71100
712	DriveOffM.Kinx.Axisy	0	71200
713	VelSmoVal.Kinx.Axisy	250.00	71300
714	LimBreakC.Kinx.Axisy	100.00	71400
715	CFilType.Kinx.Axisy.Valuea ;a = 1 to 4	0	71500
716	CLimFreq.Kinx.Axisy.Valuea ;a = 1 to 4	2000.00	71600
717	CQuaBand.Kinx.Axisy.Valuea ;a = 1 to 4	1.00	71700
718	CCentFrq.Kinx.Axisy.Valuea ;a = 1 to 4	2000.00	71800
719	ExtReleas.Kinx.Axisy	0	71900
720	DelayTime.Kinx.Axisy	200	72000
721	InConfLi.Kinx.Axisy.Valuea ;a = 1 to 4	0	72100
722	OutConfLi.Kinx.Axisy	0	72200
723	KinVelLimVal.Kinx.Axisy	100000.0	72300
724	TqLimVal.Kinx.Axisy.Valuea ;a = 1 to 4	300.00	72400

Application of the machine parameters

Parameter number	Designation	Presettings	Parameter index
725	KvFactor.Kinx.Axisy	1.00	72500
726	TqThresh.Kinx.Axisy	100.00	72600
727	BipolAccl.Kinx.Axisy	100000.0	72700
728	MonitWind.Kinx.Axisy	120.00	72800
729	DrOnDelay.Kinx.Axisy	0	72900
730	DrOfDelay.Kinx.Axisy	0	73000
731	PositAcc.Kinx.Axisy	1000.00	73100
732	VelIFFCoef.Kinx.Axisy	80.00	73200
733	DacConfL.Kinx.Axisy.Valuea ;a = 1 to 2	0	73300
734	DacCh3Max.Kinx.Axisy	0.00	73400
735	DacCh4Max.Kinx.Axisy	0.00	73500
736	SpFctBrak.Kinx.Axisy	0	73600
737	MemSavCom.Kinx.Axisy	0	73700
738	EncoderData.Kinx.Axisy	0	73800
739	FunctionEnable.Kinx.Axisy	0	73900
740	LoadcompensationTorque.Kinx.Axisy	0	74000
741	LoadcompensationVLimit.Kinx.Axisy	0	74100
742	Sd_Reserve5.Kinx.Axisy		74200
743	ThermMotorProtect.Kinx.Axisy	0	74300
744	Sd_Reserve7.Kinx.Axisy		74400
745	MotorMaxTemp.Kinx.Axisy	165.0	74500

3.3.8 Comparison table of German and English key words

The values indicated in the column “Parameter index” are parameter indexes for calling the functions in the library “MpParser.DLL”.

 **The English key words correspond (if existing) to the designations in the header files for the library functions for the access to machine parameters (rMPG.h, rMXG.h, rMPS.h, rMXS.h). The designations are extended with kinematics, axis, belt or coordinate number only if it is necessary.**

Application of the machine parameters

;x = 1.. number of kinematics

;y = 1.. axis number of the corresponding kinematic

;z = 1.. coordinate of the corresponding kinematic

;b = 1.. belt number of the corresponding kinematic

Parameter number	German designation	English designation	Parameter index
0	MPKennung	MPIidentification	0
1	AnzahlKinematiken	KinNumber	100
2	MaschinenKonfiguration	Mach_Conf	200
4	Paritaet	InpParity	400
5	Clock	ClockStTime	500
6	LaufzeitP1	RtimeMonP1	601
6	LaufzeitP2	RtimeMonP2	602
8	StrobeGANZAusganga ;a = 401 bis 416	UserStOuta ;a = 401 to 416	800
9	StrobeSystemAusgaenge	SysStrobeOut	900
10	Landessprache	SelLanguage	1000
11	AnzahlMesstaster	ProbeNumber	1100
16	IRDATAStack	IRDATAStack	1600
19	Tastengruppe	PhgKeyGroups	1900
19	PHG2000	PHGKeyDispl	1901
20	EAKonfiguration	IoHwConfig	2000
21	AnfangsAdresseSPS	StartAddrPLC	2101
21	EndAdresseSPS	EndAddrPLC	2102
21	LaufzeitUeberwachung	RTimeControlPLC	2103
21	InterbusS	InterbusS	2104
22	AFAKTORMin	RangeAfaMin	2200
22	AFAKTORMax	RangeAfaMax	2201
22	DFAKTORMin	RangeDfaMin	2202
22	DFAKTORMax	RangeDfaMax	2203
23	VFAKTORMin	RangeVfaMin	2300
23	VFAKTORMax	RangeVfaMax	2301
24	AnwenderAusgaengeLoeschen	DelUserOut	2400

Application of the machine parameters

Parameter number	German designation	English designation	Parameter index
25	AVDBeiGrundstellungKIN	AVDResetKIN	2500
25	AVDBeiAutoHandKIN	AVDAutManKIN	2501
25	AVDBeiHandAutoKIN	AVDManAutKIN	2502
25	AVDBeiProzAnwahlStartKIN	AVDProSelKIN	2503
25	AVDBeiGrundstellungGLOBAL	AVDResetGLO	2504
25	AVDBeiAutoHandGLOBAL	AVDAutManGLO	2505
25	AVDBeiHandAutoGLOBAL	AVDManAutGLO	2506
25	AVDBeiProzAnwahlStartGLOBAL	AVDProSelGLO	2507
27	StrobeGANZEingaenge	StrIntegInp	2700
30	CANAnzahlEingangsbloecke	CANInpNumb	3000
30	CANAnzahlAusgangsbloecke	CANOutNumb	3001
30	AnzahlModuleSRCAN	CANSRCNumb	3002
30	Baudrate.CANBUSa ; a = 1 bis 3	Baudrate.CANBUSa	3003
30	CANOpenDownLoad	CANOpenDownLoad	3004
30	ProtokollArt.CANBUSa ; a = 1 bis 3	ProtocolType.CANBUSa	3005
31	EingangAnfangsAdr.Blockc ; c = 1 bis 40	CANInpStAdr.Blockc	3100
31	EingangLaenge.Blockc ; c = 1 bis 40	CANInpLeng.Blockc	3101
31	EingangIdentifizier.Blockc ; c = 1 bis 40	CANInpIdent.Blockc	3102
31	EingangCANBUS.Blockc ; c = 1 bis 40	InputCANBUS.Blockc	3103
31	EingangEAArt.Blockc ; c = 1 bis 40	InputEAType.Blockc	3104
31	EingangDSSRef.Blockc ; c = 1 bis 40	InputDSSRef.Blockc	3105
32	AusgangAnfangsAdr.Blockc ; c = 1 bis 40	CANOutStAdr.Blockc	3200
32	AusgangLaenge.Blockc ; c = 1 bis 40	CANOutLeng.Blockc	3201
32	AusgangIdentifizier.Blockc ; c = 1 bis 40	CANOutIdent.Blockc	3202
32	AusgangCANBUS.Blockc ; c = 1 bis 40	OutputCANBUS.Blockc	3203
32	AusgangEAArt.Blockc ; c = 1 bis 40	OutputEAType.Blockc	3204
32	AusgangDSSRef.Blockc ; c = 1 bis 40	OutputDSSRef.Blockc	3205
34	ZeichenSchnittstellea ; a = 1 bis 4	Uart0Blocklena	3400
35	PHGMode	Phg3CompMode	3500
36	AdrMultifunktionsEingaenge	AddrMultiFuncInputs	3600
36	AdrMultifunktionsAusgaenge	AddrMultiFuncOutputs	3601
36	AdrMultifunktion2Eingaenge	AddrMultiFunc2Inputs	3602
36	AdrMultifunktion2Ausgaenge	AddrMultiFunc2Outputs	3603
37	SRCANLeselidentifizier.Blockc ; c = 1 bis 40	SRCANInpIdent.Blockc	3701
37	SRCANSchreibelidentifizier.Blockc ; c = 1 bis 40	SRCANOutIdent.Blockc	3702

Application of the machine parameters

Parameter number	German designation	English designation	Parameter index
37	SRCANCANBus.Blockc ;c = 1 bis 40	SRCANBUSNum.Blockc	3703
38	SERCOSBaudrate	SERCOSBaudrate	3800
38	SERCOSUebertragungDurchfuehren	SERCOSDownload	3801
39	KinNr.Arbeitsraume ;e = 0 bis 32 Xmin.Arbeitsraume Xmax.Arbeitsraume Ymin.Arbeitsraume Ymax.Arbeitsraume Zmin.Arbeitsraume Zmax.Arbeitsraume	KinNo.Workspacee Xmin.Workspacee Xmax.Workspacee Ymin.Workspacee Ymax.Workspacee Zmin.Workspacee Zmax.Workspacee	3901 3902 3903 3904 3905 3906 3907
101	NennNachlauf.Kinx.Achsey	NomLag.Kinx.Axisy	10100
102	MaxBahnGeschwindigkeit.Kinx	MaxPathSpeed.Kinx	10200
103	MaxAchsGeschwindigkeit.Kinx.Achsey	MaxPtpSpeed.Kinx.Axisy	10300
104	MaxSlopeBeschiPTP.Kinx.Achsey	AccIPtp.Kinx.Axisy	10400
105	SlopePunktPTP.Kinx.Achsey	SloPointPtp.Kinx.Axisy	10500
106	SatzSlopePunkt.Kinx	SlpPathBlock.Kinx	10600
106	ProgrSlopePunkt.Kinx	SlpPathProg.Kinx	10601
107	SlopePunktJOGRK.Kinx.Koordz	SloPointWc.Kinx.Coordz	10700
108	ReferenzpunktGeschw.Kinx.Achsey	RefSpeed.Kinx.Axisy	10800
109	ErsteReduzReferenzpunktGeschw.Kinx.Achsey	RefSpeed1Red.Kinx.Axisy	10900
110	ZweiteReduzReferenzpunktGeschw.Kinx.Achsey	RefSpeed2Red.Kinx.Axisy	11000
111	JOGGeschwRKLangsam.Kinx.Koordz	JogSpWcSlow.Kinx.Coordz	11100
112	JOGGeschwRKSchnell.Kinx.Koordz	JogSpWcFast.Kinx.Coordz	11200
113	JOGGeschwMKLangsam.Kinx.Achsey	JogSpJcSlow.Kinx.Axisy	11300
114	JOGGeschwMKSchnell.Kinx.Achsey	JogSpJcFast.Kinx.Axisy	11400
115	InkrSchritt1RK.Kinx	IncStWcSmall.Kinx	11500
115	InkrSchritt2RK.Kinx	IncStWcLarge.Kinx	11501
116	InkrSchritt1MK.Kinx	IncStJcSmall.Kinx	11600
116	InkrSchritt2MK.Kinx	IncStJcLarge.Kinx	11601
117	ASlopeJOG RK.Kinx.Koordz	ASlopeJogWc.Kinx.Coordz	11700
117	DSlopeJOG RK.Kinx.Koordz	DSlopeJogWc.Kinx.Coordz	11701
118	AFAKTORMin.Kinx	RangeAfaMin.Kinx	11800
118	AFAKTORMax.Kinx	RangeAfaMax.Kinx	11801
118	DFAKTORMin.Kinx	RangeDfaMin.Kinx	11802
118	DFAKTORMax.Kinx	RangeDfaMax.Kinx	11803
119	VFAKTORMin.Kinx	RangeVfaMin.Kinx	11900
119	VFAKTORMax.Kinx	RangeVfaMax.Kinx	11901

Application of the machine parameters

Parameter number	German designation	English designation	Parameter index
120	InitSlopeArt.Kinx	SlopeMode.Kinx	12000
121	BeschlForm.Kinx	SlopeForm.Kinx	12100
122	AAenderungsZeitPTP.Kinx.Achsey	ATimePtpJc.Kinx.Axisy	12200
122	DAenderungsZeitPTP.Kinx.Achsey	DTimePtpJc.Kinx.Axisy	12201
123	AAenderungsZeitRK.Kinx.Koordz	ATimeJogWc.Kinx.Coordz	12300
123	DAenderungsZeitRK.Kinx.Koordz	DTimeJogWc.Kinx.Coordz	12301
124	AAenderungsZeitBahn.Kinx	ATimeJogPath.Kinx	12400
124	DAenderungsZeitBahn.Kinx	DTimeJogPath.Kinx	12401
125	AbschaltzeitIPOStop.Kinx.Achsey	SwOffTimeIpo.Kinx.Axisy	12500
126	AbschaltzeitStillstand.Kinx.Achsey	SwOffTimeSta.Kinx.Axisy	12600
127	INPOSBereichStillstand.Kinx.Achsey	InPosStStill.Kinx.Axisy	12700
128	ASlopeJOGMK.Kinx.Achsey	ASlopeJogJc.Kinx.Axisy	12800
128	DSlopeJOGMK.Kinx.Achsey	DSlopeJogJc.Kinx.Axisy	12801
129	SlopePunktJOGMK.Kinx.Achsey	SloPointJog.Kinx.Axisy	12900
130	AAenderungsZeitJOGMK.Kinx.Achsey	ATimeJogJc.Kinx.Axisy	13000
130	DAenderungsZeitJOGMK.Kinx.Achsey	DTimeJogJc.Kinx.Axisy	13001
201	InPos.Kinx.Achsey	InPosRange.Kinx.Axisy	20100
202	SWEndschalterPositivRK.Kinx.Koordz	SwLimPosWC.Kinx.Coordz	20200
203	SWEndschalterNegativRK.Kinx.Koordz	SwLimNegWC.Kinx.Coordz	20300
204	SWEndschalterPositivMK.Kinx.Achsey	SwLimPosJc.Kinx.Axisy	20400
205	SWEndschalterNegativMK.Kinx.Achsey	SwLimNegJc.Kinx.Axisy	20500
206	SWEndschalterToleranz.Kinx.Achsey	SwLimTol.Kinx.Axisy	20600
207	ReferenzpunktISTWert.Kinx.Achsey	RefPoiPos.Kinx.Axisy	20700
208	ReferenzpunktVersatz.Kinx.Achsey	RefPoiOff.Kinx.Axisy	20800
212	UeberschleifRadius.Kinx	PassDisWc.Kinx	21200
212	UeberschleifFaktor.Kinx	PassDisJc.Kinx	21201
213	UeberschleifDistanz.Kinx.Achsey	PassDist.Kinx.Axisy	21300
214	UeberschleifArt.Kinx	PassCrit.Kinx	21400
301	KinematikName.Kinx	KinName.Kinx	30100
302	Achszahl.Kinx	KinAxisNumb.Kinx	30200
303	AchsTyp.Kinx.Achsey	AxisType.Kinx.Axisy	30300
304	AchsName.Kinx.Achsey	AxisName.Kinx.Axisy	30400
305	KoordinatenName.Kinx.Koordz	AxisCoord.Kinx.Coordz	30500
306	RoboterTyp.Kinx	KinRobType.Kinx	30600
306	AlleAchsenReferieren.Kinx	KinRefAllAx.Kinx	30601

Application of the machine parameters

Parameter number	German designation	English designation	Parameter index
306	IPOSaufnahme.Kinx	KinIposCoord.Kinx	30602
306	IPOSlesen.Kinx	KinIposComm.Kinx	30603
306	EndlosachsenHB.Kinx	KinEndless.Kinx	30604
306	Achsueberwachung.Kinx	KinAxisConWc.Kinx	30605
307	Achslaenge.Kinx.Arma ;a = 1 bis 8	KinAxisLeng.Kinx.Arma	30700
308	KopplungsFaktor.Kinx.Faktora ;a = 1 bis 8	KinCoupFact.Kinx.Factora	30800
309	Flansch_X.Kinx Flansch_Y.Kinx Flansch_Z.Kinx Flansch_O1.Kinx Flansch_O2.Kinx Flansch_O3.Kinx	KinFlangeCooX.Kinx KinFlangeCooY.Kinx KinFlangeCooZ.Kinx KinFlangeCooO1.Kinx KinFlangeCooO2.Kinx KinFlangeCooO3.Kinx	30900 30901 30902 30903 30904 30905
310	VerschiebungRKSystem_X_0.Kinx VerschiebungRKSystem_Y_0.Kinx VerschiebungRKSystem_Z_0.Kinx VerschiebungRKSystem_O1_0.Kinx VerschiebungRKSystem_O2_0.Kinx VerschiebungRKSystem_O3_0.Kinx	KinWcCoorOffX.Kinx KinWcCoorOffY.Kinx KinWcCoorOffZ.Kinx KinWcCoorOffO1.Kinx KinWcCoorOffO2.Kinx KinWcCoorOffO3.Kinx	31000 31001 31002 31003 31004 31005
311	ModuloWert.Kinx.Achsey	ModValue.Kinx.Axisy	31100
313	RKSystem_x.Kinx RKSystem_y.Kinx RKSystem_z.Kinx RKSystem_a.Kinx RKSystem_b.Kinx RKSystem_c.Kinx	KinWcSysAssgx.Kinx KinWcSysAssgy.Kinx KinWcSysAssgz.Kinx KinWcSysAssga.Kinx KinWcSysAssgb.Kinx KinWcSysAssgc.Kinx	31300 31301 31302 31303 31304 31305
314	Seriennummer.Kinx	Seriesnumber.Kinx	31400
401	ServoKarte.Kinx.Achsey	SbNum.Kinx.Axisy	40100
401	ServoKarte.Kinx.Bandb	SbNum.Kinx.Beltb	40120
401	SteckerNummer.Kinx.Achsey	SlotNum.Kinx.Axisy	40101
401	SteckerNummer.Kinx.Bandb	SlotNum.Kinx.Beltb	40121
401	ModulNummer.Kinx.Achsey	ModulNum.Kinx.Axisy	40102
401	ModulNummer.Kinx.Bandb	ModulNum.Kinx.Beltb	40122
401	INCMarkerAbstand.Kinx.Achsey	IncMarkDis.Kinx.Axisy	40103
401	INCMarkerAbstand.Kinx.Bandb	IncMarkDis.Kinx.Beltb	40129
401	CANGetriebeFaktor.Kinx.Achsey	CANGearFac.Kinx.Axisy	40104
401	CANPulseProUmdrehung.Kinx.Achsey	CANResPCount.Kinx.Axisy	40105
401	CANPulseProUmdrehung.Kinx.Bandb	CANResPCount.Kinx.Beltb	40136
401	CANModuloWert.Kinx.Achsey	CANModuloValue.Kinx.Axisy	40130
401	CANModuloWert.Kinx.Bandb	CANModuloValue.Kinx.Beltb	40131

Application of the machine parameters

Parameter number	German designation	English designation	Parameter index
401	CANWegProGeberUmdrehung.Kinx.Achsey	CANDistancePerRevolution.Kinx.Axisy	40132
401	MessSystemBewertung.Kinx.Achsey	MeaSysFactor.Kinx.Axisy	40106
401	MessSystemBewertung.Kinx.Bandb	MeaSysFactor.Kinx.Belbtb	40123
401	SollWertAusgang.Kinx.Achsey	ComOutput.Kinx.Axisy	40107
401	CANEingang.Kinx.Achsey	CANModAxNum.Kinx.Axisy	40112
401	CANEingang.Kinx.Bandb	CANModAxNum.Kinx.Belbtb	40133
401	CANAntriebsArt.Kinx.Achsey	CANDriveMode.Kinx.Axisy	40113
401	CANAntriebsArt.Kinx.Bandb	CANDriveMode.Kinx.Belbtb	40134
401	CANAnzahlUmdrehungen.Kinx.Achsey	CANPulseRate.Kinx.Axisy	40114
401	CANAnzahlUmdrehungen.Kinx.Bandb	CANPulseRate.Kinx.Belbtb	40135
401	CANReferenzMode.Kinx.Achsey	CANRefMode.Kinx.Axisy	40115
401	CANNullpunktVerschiebung.Kinx.Achsey	CANOffset.Kinx.Axisy	40124
401	CANNullpunktVerschiebung.Kinx.Bandb	CANOffset.Kinx.Belbtb	40137
401	CANDSSRef.Kinx.Achsey	CANDSSRef.Kinx.Axisy	40125
401	CANDSSRef.Kinx.Bandb	CANDSSRef.Kinx.Belbtb	40138
401	CANNodeID.Kinx.Achsey	CANNodeID.Kinx.Axisy	40147
401	CANNodeID.Kinx.Bandb	CANNodeID.Kinx.Belbtb	40148
401	SERCOSAntriebsArt.Kinx.Achsey	SERCOSDriveMode.Kinx.Axisy	40126
401	SERCOSAntriebsArt.Kinx.Bandb	SERCOSDriveMode.Kinx.Belbtb	40139
401	SERCOSEingang.Kinx.Achsey	SERCOSModAxNum.Kinx.Axisy	40140
401	SERCOSEingang.Kinx.Bandb	SERCOSModAxNum.Kinx.Belbtb	40141
401	SERCOSReferenzMode.Kinx.Achsey	SERCOSRefMode.Kinx.Axisy	40142
401	SERCOSGetriebeFaktor.Kinx.Achsey	SERCOSGearFac.Kinx.Axisy	40143
401	SERCOSModuloWert.Kinx.Achsey	SERCOSModuloValue.Kinx.Axisy	40144
401	SERCOSModuloWert.Kinx.Bandb	SERCOSModuloValue.Kinx.Belbtb	40145
401	SERCOSWegProGeberUmdrehung.Kinx.Achsey	SERCOSDistancePerRevolution.Kinx.Axisy	40146
401	SERCOSRing.Kinx.Achsey	SERCOSRing.Kinx.Axisy	40149
401	SERCOSRing.Kinx.Bandb	SERCOSRing.Kinx.Belbtb	40150
402	RefPunktRichtung.Kinx.Achsey	RefDir.Kinx.Axisy	40200
403	WirksamkeitRefPunktSchalter.Kinx.Achsey	RefPoiSwT.Kinx.Axisy	40300
404	AnzahlAnalogAusgaenge	NumberAnalogOutputs	40400
405	AnalogAusgangBelegung.Ausganga	AnalogOutAlloc.Outputa	40501
405	AnalogAusgangAnfangsAdresse.Ausganga	AnalogOutStartAddr.Outputa	40502
405	AnalogAusgangFormat.Ausganga	AnalogOutFormat.Outputa	40503

Application of the machine parameters

Parameter number	German designation	English designation	Parameter index
405	AnalogAusgangNennwert.Ausganga	AnalogOutNominalValue.Outputa	40504
405	AnalogAusgangSpannungsOffset.Ausganga	AnalogOutVoltageOffset.Outputa	40505
406	AnzahlAnalogEingaenge	NumberAnalogInput	40600
407	AnalogEingangBelegung.Einganga	AnalogInAlloc.Inputa	40701
407	AnalogEingangAnfangsAdresse.Einganga	AnalogInStartAddr.Inputa	40702
407	AnalogEingangFormat.Einganga	AnalogInFormat.Inputa	40703
407	AnalogEingangNennwert.Einganga	AnalogInNominalValue.Inputa	40704
501	Bandzahl.Kinx	KinBeltNumb.Kinx	50100
503	BandKopplungsfaktor.Kinx.Bandb.Koordz	BeltDirCos.Kinx.Beltb.Coordz	50300
505	MinGrenzwertBand.Kinx.Bandb	BeltCoLimMin.Kinx.Beltb	50501
505	MaxGrenzwertBand.Kinx.Bandb	BeltCoLimMax.Kinx.Beltb	50502
506	BandName.Kinx.Bandb	BeltName.Kinx.Beltb	50600
507	BandVorhalteZeit.Kinx.Bandb	BeltTimeOff.Kinx.Beltb	50700
508	BandSimulationsGeschw.Kinx.Bandb	BeltSimVel.Kinx.Beltb	50800
509	BandIstWertSollWert.Kinx.Bandb	BeltActualValueSetValue.Kinx.Beltb	50900
601	UebertragungDurchfuehren	DIAntrPar	60100
602	VerstaerkerTyp.Kinx.Achsey	ControllerId.Kinx.Axisy	60200
603	MotorTyp.Kinx.Achsey	MotorId.Kinx.Axisy	60300
604	PAnteilGeschwRegler.Kinx.Achsey	VelGain.Kinx.Axisy	60400
605	IAnteilGeschwRegler.Kinx.Achsey	VelTi.Kinx.Axisy	60500
606	KVLageRegler.Kinx.Achsey	PropGain.Kinx.Axisy	60600
607	AUTOSTromGrenze.Kinx.Achsey	AutoTorqueLi.Kinx.Axisy	60700
607	HANDSTromGrenze.Kinx.Achsey	ManTorqueLi.Kinx.Axisy	60701
607	NOTAUSSTromGrenze.Kinx.Achsey	EmTorqueLi.Kinx.Axisy	60702
608	NOTAUSVerzoegerung.Kinx.Achsey	EmDecelerat.Kinx.Axisy	60800
609	BremsGesch.Kinx.Achsey	EmBreaking.Kinx.Axisy	60900
610	MaxStatPosFehler.Kinx.Achsey	StaticErr.Kinx.Axisy	61000
611	MaxNachlaufFehler.Kinx.Achsey	KevSi.Kinx.Axisy	61100
612	Filter.Bandbreite.Kinx.Achsey	FnTorque.Kinx.Axisy	61200
613	Daempfungsfaktor.Kinx.Achsey	ZTorque.Kinx.Axisy	61300
614	NullPunktVerschiebung.Kinx.Achsey	HomePosOff.Kinx.Axisy	61400
615	UebertempSchutz.Kinx.Achsey	EnTempProt.Kinx.Axisy	61500
701	Uebertragung Durchfuehren	DIAntrPar	70100
702	Hauptbetriebsart.Kinx.Achsey	PrimOpMod.Kinx.Axisy	70200

Application of the machine parameters

Parameter number	German designation	English designation	Parameter index
703	DrehzahlPVerstaerker.Kinx.Achsey	VelProp.Kinx.Axisy	70300
704	DrehzahlreglerNachstellzeit.Kinx.Achsey	VelIntTim.Kinx.Axisy	70400
705	StromreglerPVerstaerkung1.Kinx.Achsey	C1PropReg.Kinx.Axisy	70500
706	StromreglerNachstellzeit1.Kinx.Achsey	C1IntTime.Kinx.Axisy	70600
707	StromreglerPVerstaerkung2.Kinx.Achsey	C2PropReg.Kinx.Axisy	70700
708	StromreglerNachstellzeit2.Kinx.Achsey	C2IntTime.Kinx.Axisy	70800
709	VerstaerkerWarnTemp.Kinx.Achsey	AmplWTemp.Kinx.Axisy	70900
710	MotorWarnTemp.Kinx.Achsey	MotoWTemp.Kinx.Axisy	71000
711	SchaltfreqLeistungsendstufe.Kinx.Achsey	PowOutFrq.Kinx.Axisy	71100
712	StillsetzungAntriebAus.Kinx.Achsey	DriveOffM.Kinx.Axisy	71200
713	IstwertGlaettungDRegler.Kinx.Achsey	VelSmoVal.Kinx.Axisy	71300
714	BremsstromBegrenzung.Kinx.Achsey	LimBrakeC.Kinx.Axisy	71400
715	Filtertyp.Kinx.Achsey.Werta ;a = 1 bis 4	CFilType.Kinx.Axisy.Valuea	71500
716	GrenzfreqTiefpass.Kinx.Achsey.Werta ;a = 1 bis 4	CLimFreq.Kinx.Axisy.Valuea	71600
717	GueteBandsperr.Kinx.Achsey.Werta ;a = 1 bis 4	CQuaBand.Kinx.Axisy.Valuea	71700
718	MittenfreqBandsperr.Kinx.Achsey.Werta ;a = 1 bis 4	CCentFrq.Kinx.Axisy.Valuea	71800
719	SteuerwortExterneFreigabe.Kinx.Achsey	ExtReleas.Kinx.Axisy	71900
720	Freigabeverzoeigerung.Kinx.Achsey	DelayTime.Kinx.Axisy	72000
721	InportKonfig.Kinx.Achsey.Werta ;a = 1 bis 4	InConfLi.Kinx.Axisy.Valuea	72100
722	OutportKonfig.Kinx.Achsey	OutConfLi.Kinx.Axisy	72200
723	GeschwGrenzwertBipolar.Kinx.Achsey	KinVelLimVal.Kinx.Axisy	72300
724	DrehmomentGrenzwertBipolar.Kinx.Achsey.Werta ;a = 1 bis 4	TqLimVal.Kinx.Axisy.Valuea	72400
725	KVFaktor.Kinx.Achsey	KvFactor.Kinx.Axisy	72500
726	DrehmomentSchwelle.Kinx.Achsey	TqThresh.Kinx.Axisy	72600
727	BeschlBipolar.Kinx.Achsey	BipolAccl.Kinx.Axisy	72700
728	Ueberwachungsfenster.Kinx.Achsey	MonitWind.Kinx.Axisy	72800
729	WartezeitAntriebEin.Kinx.Achsey	DrOnDelay.Kinx.Axisy	72900
730	WartezeitAntriebAus.Kinx.Achsey	DrOfDelay.Kinx.Axisy	73000
731	PositionierBeschl.Kinx.Achsey	PositAcc.Kinx.Axisy	73100
732	BewertungGeschwVorsteuerung.Kinx.Achsey	VelFFCoef.Kinx.Axisy	73200
733	DACKonfListe.Kinx.Achsey.Werta ;a = 1 bis 2	DacConfL.Kinx.Axisy.Valuea	73300
734	DACKanal3MaxWert.Kinx.Achsey	DacCh3Max.Kinx.Axisy	73400
735	DACKanal4MaxWert.Kinx.Achsey	DacCh4Max.Kinx.Axisy	73500
736	SpezFktBremse.Kinx.Achsey	SpFctBrak.Kinx.Axisy	73600

Application of the machine parameters

Parameter number	German designation	English designation	Parameter index
737	ArbeitsspeicherSichern.Kinx.Achsey	MemSavCom.Kinx.Axisy	73700
738	GeberDaten.Kinx.Achsey	EncoderData.Kinx.Axisy	73800
739	Funktionsfreischaltung.Kinx.Achsey	FunctionEnable.Kinx.Axisy	73900
740	Lastausgleichsmoment.Kinx.Achsey	LoadcompensationTorque.Kinx.Axisy	74000
741	LastausgleichsmomentVGrenze.Kinx.Achsey	LoadcompensationVLimit.Kinx.Axisy	74100
742	Reserve5.Kinx.Achsey	Sd_Reserve5.Kinx.Axisy	74200
743	ThermMotorschutzFaktor.Kinx.Achsey	ThermMotorProtect.Kinx.Axisy	74300
744	Reserve7.Kinx.Achsey	Sd_Reserve7.Kinx.Axisy	74400
745	MotorAbschalttemperatur.Kinx.Achsey	MotorMaxTemp.Kinx.Axisy	74500

General system parameters

4 General system parameters

Group 0	General system parameters
P1	Number of kinematics
P2	Machine configuration
P3	Reserved
P4	Parity for INTEGER inputs at the interface
P5	Clock start time (interpolation clock, transformation clock)
P6	Runtime monitoring
P7	Reserved
P8	Strobe times for INTEGER-user-outputs
P9	Strobe time for system outputs
P10	Language selection
P11	Number of probes
P12	Reserved
P13	Reserved
P14	Reserved
P15	Reserved
P16	IRDATA stack size
P17	Reserved
P18	Reserved
P19	Number of PHG key groups
P20	I/O assembly configuration
P21	PLC parameters
P22	Global A-/DFACTOR range
P23	Global VFACTOR range
P24	Deletion of user outputs
P25	Reset of the A/D/V-factors
P26	Reserved
P27	Strobe INTEGER inputs
P28	Display of options available
P29	Reserved

General system parameters

Group 0	General system parameters
P30	I/O configuration of the CAN bus
P31	Address ranges of the CAN inputs
P32	Address ranges of the CAN outputs
P33	Reserved
P34	Number of characters for a set handshake
P35	PHG mode
P36	Multi-function I/O
P37	Electronic type plate
P38	SERCOS interface
P39	Workingspace monitoring

All parameters can either be changed via the PHG2000 (Mode 7.8.2) or via the machine parameter converter ASCII to MP which is a component of ROPS4/Online.

The entry for the ASCII file to be converted can always be found below the corresponding PHG picture.

General system parameters

P1 Number of kinematics

Up to 16 different kinematics can be controlled.

The number of kinematics can be changed in steps of one, the default number is 1.

If the number of kinematics is increased, parameters 301 and 306 are selected automatically.

Display on the PHG

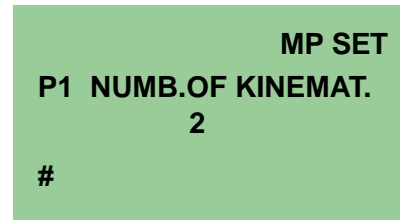

MP SET
P1 NUMB.OF KINEMAT.
2
#

Entry in converter file

P1.KinNumber=2

P2 Machine configuration

The value in P2x (0 to 255) is put out coded at the RC-internal interface. With this information it is possible to control machine-specific processes in PLC programs.

Display on the PHG

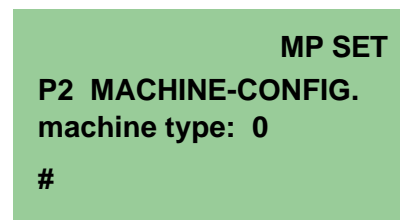

MP SET
P2 MACHINE-CONFIG.
machine type: 0
#

Entry in converter file

P2.Mach_Conf=0

General system parameters

P4 Parity for INTEGER inputs at the interface

With P4 the parity for the BAPS input data channels of the type INTEGER as well as for external program selection is defined.

Possible entries are:
0 = none (default)
1 = odd
2 = even

Display on the PHG

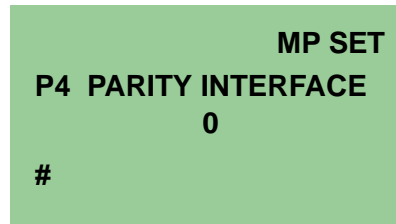

MP SET
P4 PARITY INTERFACE
0
#

Entry in converter file

P4.InpParity=0

 **RC-outputs are put out with an even parity.**

General system parameters

P5 Clock Start time (clocked operation)

 **The machine parameter P5 Clock start time is a system parameter with far-reaching effect. It defines among others the I/O reaction times of the rho4 and must be adjusted as small as possible and as high as necessary.**

The minimal admissible value depends on:

- the type of the drive amplifier
- the windows calculating time resp. admissible Windows latency
- the running time of the PLC program
- the calculating base load, the number of the kinematics and the total number of axes

Calculation of the clock start time (applies to most application cases):

$$\text{Clock start time[ms]} = 100 / (100 - \text{Windows calculating time in \%}) * (1,1 + 0,2 * \text{KinNumber} + \text{PCL running time})$$

The Windows calculation time or admissible Window latency

Windows and the real-time part run in the rho4.1 on the same processor. The real-time part has a higher priority as Windows. Windows loses the calculation time of the real-time part.

Since Windows has however some tasks executed by performant controllers such as the graphic card or the hard-disk controller, the processor of Windows is not working to full capacity and waits e.g. for messages of its controller. If a part of the processor performance is used by the real-time part, this has only the consequence in some cases that waiting times for the controllers are usefully used and the user reaction gets worse only slightly.

If it is wished to make computer-bound applications run either in Windows or in real-time part, it may become necessary to change the standard adjusted calculation time distribution to 50 %.

At WinPanel the Windows calculation time can be modified under 'Administration - Change system parameter'.

The running time of the PCL program

In the operation rho4.1 with PCL, the PCL program is run once per clock start time at the maximum. The edition of the PCL program has a higher priority as the edition of BAPS application programs.

The running time of the PCL program is dynamically displayed at the PHG under Mode 7.3.5. The time between the beginning of the PCL program and the end of the PCL program. Interruption of the PCL program, e.g. through real-time interrupts or download to Windows are not deduced.

General system parameters

During the start of the PCL, a relatively high running time is required. Through a STOP/RUN conversion, a new time acquisition is started which better determines the real maximum value.

If the PCL program runs longer than 1 millisecond, the download to Windows can prolong the running time displayed at the PHG rapidly by e.g 1 millisecond.

Calculation base load, number of kinematics, total number of axes

The total number of axes has a small effect on the calculation base load. It is however important for the allocation of the CAN buses. Especially, both CAN buses should be configured in an as balanced as possible way so that the interrupt operation for both CAN controllers can be dropped.

The number of the kinematics increases the calculation base load by approx. 200 microseconds per kinematic. For settings in the 1 or 2 millisecond grid, this factor is negligible in a lot of cases.

The calculation base load is approx. 1.1 millisecond on the rho4.1 with 200 MHz version. In this time, times are grouped for the communication with the drives and the CAN-I/O, interpolation, monitoring functions and the data exchange with the PCL.

Examples

With 2 kinematics and a PCL running time of 0.5 millisecond, the calculation time needed for the real-time part is 2 milliseconds ($1,1 + 0,2 * 2 + 0,5$). As clock start time for the different Windows calculation times, the results are:

- 10 % $100 / 90 * 2 = 2,22$ milliseconds:
Limit case Servodyn D with CAN => 4 milliseconds
- 25 % $100 / 75 * 2 = 2,66$ milliseconds,
Limit case Servodyn D with CAN => 4 milliseconds
- 50 % $100 / 50 * 2 = 4,00$ milliseconds,
Limit case Servodyn D with CAN => 4 milliseconds
- 75 % $100 / 25 * 2 = 8,00$ milliseconds => 8 milliseconds
- 90 % $100 / 10 * 2 = 20,00$ milliseconds => 20 milliseconds

 **Only integer milliseconds are allowed.**

With Servodyn-G drive amplifiers, the minimum admissible clock start time is 10 milliseconds.

Indication for CAN-Axes

With Servodyn-D drive amplifiers coupled via CAN bus, only even clock start times ≥ 4 milliseconds are allowed, i.e. 4, 6, 8, 10, etc. For over 12 axes at the same CAN bus or corresponding number of I/O knots, 8 milliseconds at least must be adjusted.

General system parameters

To transfer a change of the clock start time to the drive amplifiers, the parameter download must be switched on at the drive amplifiers (machine parameter 601 or 701).

Display PHG



MP SET
P5 CLOCK START-TIME
10 ms
#

Entry in converter file

P5.ClockStTime=10

P6 Runtime monitoring

With P6 the runtime between the operation and preparation logic (P1) and the servo loop logic (P2) is monitored. The input is in ms.

If the runtime is exceeded because of an error, the following error messages appear

- CP1 not updated,
- P1 runtime error,
- System error 2 P2 not running or
- Runtime error.

 **The default value for this parameter must not be changed without consulting Bosch.**

Display on the PHG

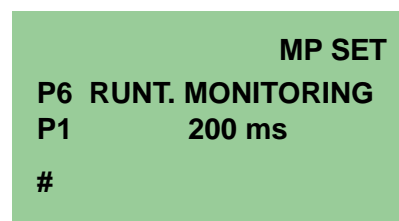

MP SET
P6 RUNT. MONITORING
P1 200 ms
#

Entry in converter file

P6.RtimeMonP1=200

General system parameters

Display on the PHG

```

MP SET
P6 RUNT. MONITORING
P2      200 ms
#

```

Entry in converter file

```
P6.RtimeMonP2=200
```

P8 Strobe times for INTEGER user outputs

With P8 the strobe time for the max. 16 INTEGER user outputs is defined. Each INTEGER output consists of 8 bits.

The user output can be programmed with BAPS. For instance the output of a coded control information. If in the BAPS user program an INTEGER output is active, the data are available for the user together with the corresponding strobe signal in the RC internal interface at least for the duration of the strobe time.

The strobe signal is present together with the information of the INTEGER data channel.

- The minimum strobe time should not be less than the double turnaround time of the receive device, as otherwise the signal might not be recognized.
- The value must be a multiple of P5.
- The shortest time corresponds to the value of P5, the longest time is 10000 ms.
- By input of -1 the strobe time can be disabled.

Display on the PHG

```

MP SET
P8 STRB. INT. US.OUT
OUTPUT 401  110 ms
#

```

Entry in converter file

```
P8.UserStOut401=110
```

 **The strobe times must be entered for the outputs 401 to 416.**

General system parameters

P9 Strobe time system outputs

With P9 the strobe time for system outputs is defined. The input is in ms. This affects the following:

- Strobe for coded error output
- Acknowledgement of program selection
- Error signal for program selection
- Acknowledgement of coded text output
- Error in coded text output
- Initial position has been selected
- Coded pause

Display on the PHG

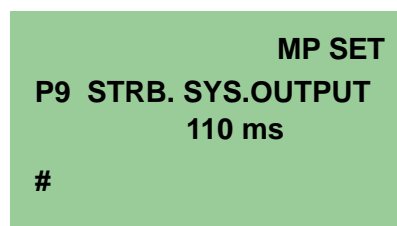

MP SET
P9 STRB. SYS.OUTPUT
110 ms
#

Entry in converter file

P9.SysStrobeOut=110

P10 Language selection

With P10 the language for the BAPS programming as well as for all operating and message texts is set.

0 = German
1 = English

Display on the PHG

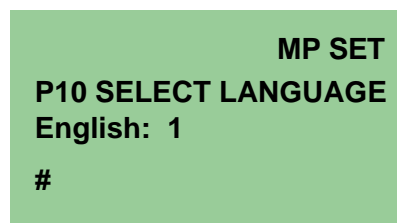

MP SET
P10 SELECT LANGUAGE
English: 1
#

Entry in converter file

P10.SelLanguage=1

General system parameters

P11 Number of probes

With P11 the number of probes is defined.

Display on the PHG

```

MP SET
P11 PROBE-INPUT
SB1 No.of Probeln:0
#
  
```

Entry in converter file

P11.ProbeNumber=0

P16 IRDATA stack size

For the intermediate storing of variables, e.g. for subroutine calls, a separate storing location is required. The input is in kbytes.

The location defined here is made available for every user process by the system heap.

Display on the PHG

```

MP SET
P16 SIZE IRD-STACK
1.000 k-Byte
#
  
```

Entry in converter file

P16.IRDATAStack=1.000

P19 Number of the PHG key groups

To be able to move several kinematics in manual mode with one PHG, it is necessary to divide the keys for moving the axes into groups.

The twelve Jog keys can be divided into groups. If more than six axes belong to one kinematic, or generally more than six axes are available, more than one group must be defined. A maximum of 16 PHG key groups is possible.

Example 1

One kinematic with seven axes and two groups

- Group 1: axes 1–6 (keys 1–6 +/-)
- Group 2: axis 7 (key 1 +/-)

General system parameters

Display on the PHG

```
MP SET
P19 PHG-KEY-GROUPS
PHG key groups:  2
#
```

Entry in converter file

P19.PhgKeyGroups=2

Example 2

Three kinematics with two axes each and one group. In this example, three kinematics are controlled via one group.

- Axis keys 1 and 2 (+/-) kinematic 1
- Axis keys 3 and 4 (+/-) kinematic 2
- Axis keys 5 and 6 (+/-) kinematic 3

Display on the PHG

```
MP SET
P19 PHG-KEY-GROUPS
PHG key groups:  1
#
```

Entry in converter file

P19.PhgKeyGroups=1

Example 3

Three kinematics with two axes each and three groups
Axis keys 1 and 2 (+/-) Selection: group 1 and kinematic 1
Axis keys 1 and 2 (+/-) Selection: group 2 and kinematic 2
Axis keys 1 and 2 (+/-) Selection: group 3 and kinematic 3

Display on the PHG

```
MP SET
P19 PHG-KEY-GROUPS
PHG key groups:  3
#
```

Entry in converter file

P19.PhgKeyGroups=3

General system parameters

For displaying the preset groups during Teach In, the following inquiry must be set to 1. If the value 0 is set, no groups are displayed in Teach In mode. Presetting is 0.

Display on the PHG

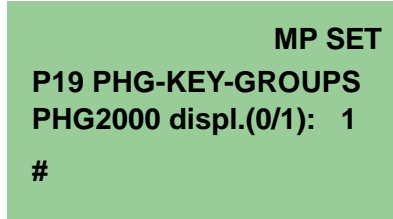

```
MP SET
P19 PHG-KEY-GROUPS
PHG2000 displ.(0/1): 1
#
```

Entry in converter file

P19.PHGKeyDispl=1

P20 I/O assembly group configuration

There are different possibilities of the PCL coupling:

Configuration 0

Configuration 40 Automatic assembly group identification (internal PCL)

Configuration 41 Coupling via TCP/IP,
automatic PCL shutdown during rho4.1 shutdown
(external PLC)

Configuration 42 Coupling via TCP/IP,
no automatic PCL-Shutdown
during rho4.1 shutdown (external PCL)

Display on the PHG

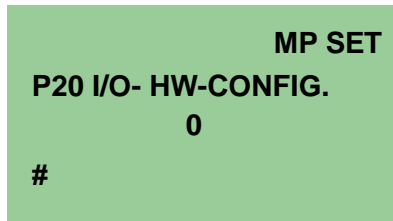

```
MP SET
P20 I/O- HW-CONFIG.
0
#
```

Entry in converter file

P20.IOHwConfig=0

P21 PLC parameters

With P21 the start and end address of the rho4 interface inputs and outputs, as well as the time monitoring for the PCL data exchange are set.

General system parameters

Predefined are:

Start address I/O	0
End address I/O	255
Time monitoring	250

This means that 256 bytes can normally be copied from the rho4 to the PCL and 256 bytes from the PCL to the rho4.

This always takes place after the termination of a PLC program.

☞ If the start address is changed, the end address must also be changed in the same way. If this is not done, only that rho4 range, which results from the difference between the end address and the start address, is copied from and to the PCL.

Only rho4.0:

When using a PCI-BM-IBS component for the operation of the PCLrho4.0 with INTERBUS-S, the I/O configuration can be adjusted via this parameter.

At the moment there are the following possibilities of setting:

- 0 physical addressing of the inputs/outputs
- 32 configuration of the Phoenix Contact company by means of CMD

Display on the PHG

```

MP SET
P21 PCL PARAMETERS
I/O START:    0
#

```

Entry in converter file

P21.StartAddrPLC=0

Display on the PHG

```

MP SET
P21 PCL PARAMETERS
I/O END:      255
#

```

General system parameters

Entry in converter file

P21.EndAddrPLC=255

Display on the PHG

```

MP SET
P21 PCL PARAMETERS
WATCHDOG: 250
#
    
```

Entry in converter file

P21.RTimeControlPLC=250

Only rho4.0:

Display on the PHG

```

MP SET
P21 PCL PARAMETERS
INTERBUS-S: 0
#
    
```

Entry in converter file

P21.InterbusS=0

P22 Range of global A-/DFACTOR

With P22 the input range of the acceleration and the deceleration factor is limited. It can be set via the help functions of the PHG2000 with mode 11.x, resp. via interface signals.

The limitation acts globally and applies to all kinematics.

Input range: 0.0001 to 9.9999 (0,01 % to 999,99 %), the range is predefined with 1 upon delivery (100 %).

$$A_{act} = A_{BAPS} * AFACTOR_{(dep. of P118)} * AFACTOR_{PHG/Interf. (dep. of P22)}$$

Display on the PHG

```

MP SET
P22 GLOBAL.A/DFACTOR
minimum AFA 0.001
#
    
```

```

MP SET
P22 GLOBAL.A/DFACTOR
maximum AFA 9.999
#
    
```

General system parameters

Entry in converter file

P22.RangeAfaMin=0.001
P22.RangeAfaMax=9.999

Display on the PHG

MP SET	
P22 GLOBAL.A/DFACTOR	
minimum DFA	0.001
#	

MP SET	
P22 GLOBAL.A/DFACTOR	
maximum DFA	9.999
#	

Entry in converter file

P22.RangeDfaMin=0.001
P22.RangeDfaMax=9.999

P23 Range of global VFACTOR

With P23 the input range for the velocity factor is limited. It can be set via the help functions of the PHG2000 with mode 11.x, resp. via interface signals.

The limitation acts globally and applies to all kinematics.

Input range: 0.001 to 9.999 (0.1 % to 999.9 %), the range is predefined with 1 upon delivery (100 %).

$$V_{act} = V_{BAPS} * VFACTOR_{(dep. of. P119)} * VFACTOR_{PHG/Interf. (dep. of P23)}$$

Display on the PHG

MP SET	
P23 GLOB.RANGE VFACT	
minimum	0.001
#	

MP SET	
P23 GLOB.RANGE VFACT	
maximum	9.999
#	

Entry in converter file

P23.RangeVfaMin=0.001
P23.RangeVfaMax=9.999

General system parameters

P24 Deletion of user outputs

With P24 it is defined up to which user output the outputs are to be deleted by reset.

The deletion of all user outputs is preset upon delivery.

Example

- The set value is 199, i.e. all user outputs up to and including 199 are set to 0 by reset.
- If the value 100 is set, the statuses of the outputs 101 to 199 are not changed by reset.

Display on the PHG

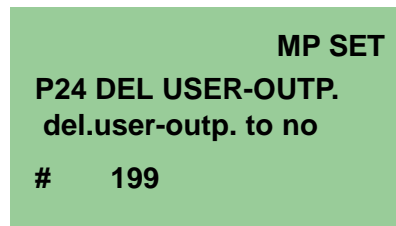

Entry in converter file

P24.DelUserOut=199

P25 Reset of the A/D/V factors

With P25 the reset behavior of the global and kinematic-dependent A/D/V-factors is defined. Admissible inputs are 0 and 1.

The following table shows the mode of operation of the default settings (all 0) of the individual factors:

Operation	Global factors	Kin. dep. factors
Initial position	1.0 (100 %)	unchanged
Auto ==> Hand	unchanged	unchanged
Manual ==> Auto	unchanged	unchanged
Process selection	unchanged	1.0 (100 %)

With 1 the preset behaviour is changed:

Operation	Global factors	Kin. dep. factors
Initial position	unchanged	1.0
Auto ==> Hand	1.0 (100 %)	1.0
Manual ==> Auto	1.0 (100 %)	1.0
Process selection	1.0 (100 %) (*)	unchanged

The change marked with * acts on all kinematics, i.e. including the kinematics already moved in a process.

General system parameters

Display on the PHG

MP SET

**P25 RESET V/A/D-FACT
kin. subj. factors
Reset(PHG/IF): 0 #**

MP SET

**P25 RESET V/A/D-FACT
global A/D/V-factors
Reset(PHG/IF): 0 #**

Entry in converter file

P25.AVDResetKIN=0
P25.AVDResetGLO=0

Display on the PHG

MP SET

**P25 RESET V/A/D-FACT
kin. subj. factors
AUTO==>HAND: 0 #**

MP SET

**P25 RESET V/A/D-FACT
global A/D/V-factors
AUTO==>HAND: 0 #**

Entry in converter file

P25.AVDAutManKIN=0
P25.AVDAutManGLO=0

Display on the PHG

MP SET

**P25 RESET V/A/D-FACT
kin. subj. factors
HAND==>AUTO: 0 #**

MP SET

**P25 RESET V/A/D-FACT
global A/D/V-factors
HAND==>AUTO: 0 #**

Entry in converter file

P25.AVDManAutKIN=0
P25.AVDManAutGLO=0

Display on the PHG

General system parameters

MP SET

P25 RESET V/A/D-FACT
kin. subj. factors
Proc.Sel/START: 0 #

MP SET

P25 RESET V/A/D-FACT
global A/D/V-factors
Proc.Sel/START: 0 #

Entry in converter file
P25.AVDProSelKIN=0
P25.AVDProSelGLO=0

P27 Strobe INTEGER inputs

With P27 the strobe for the INTEGER inputs can be switched On or Off.

Possible entries are:
0 = with strobe (default)
1 = without strobe

Display on the PHG

MP SET

P27 STROBE INT.-INP.
(strobe enable = 0,
strobe disable=1): 0 #

Entry in converter file
P27.StrIntegInp=0

P28 Display of available options

With the selection of P28 the values for all set options are displayed. The value is displayed in hexadecimal form with two digits.

The display begins with the first set option of the option list and ends with the last set option, max. 64. The options which can be changed per parameter or which are not used are not displayed.

In P28 no cursor is shown. Only the keys

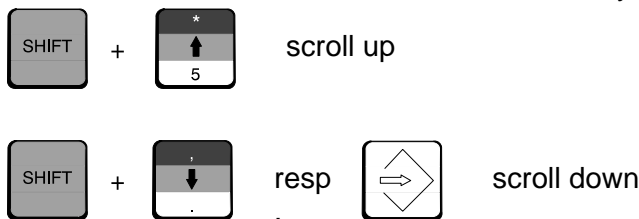

are allowed. Other inputs generate an error message.

General system parameters

Display on the PHG

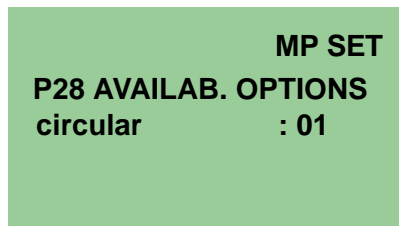
A screenshot of a green rectangular display area. The text is white and arranged in four lines: 'MP SET' on the top line, 'P28 AVAILAB. OPTIONS' on the second line, 'circular' on the third line, and ': 01' on the fourth line.

MP SET
P28 AVAILAB. OPTIONS
circular **: 01**

 **Option bytes must only be changed by authorized personnel and after consultation with Bosch. Wrong option values can lead to malfunctions of the control.**

General system parameters

Example of the display under P28

Activated options	Value
circular	01
mirror	01
gripper-coord.	01
file-I/O	01
linear-interp.	01
program slope	01
sinus*2-slope	01
cod. text.,MSD	01
tool	01
A/D/V-factor IF	01
read POS	01
several kin.	01
coupl.-coord.	01
FA witho.ref-p.	01
decel.progslope	01
logbook	01
passing	01
3964R protocol	01
min.p clocknumb	03
global data	01
decel. passing	01
toler.driveoff	02
set machpos.	01
online-funct.	01
Spec.Fct. clock	01
BSYN: cam disk	01
PKT overwrite	01
Store Us.memory	01
BS: 'TO' wo.INPOS	01
PHG-Fct. via IF	01
moving history	01
BSYN witho.axis	01
No.of CAN-Ax.>6	01
WC-System activ	01

General system parameters

P30 I/O configuration of the CAN bus

With P30 the total number of the digital and analog input and output blocks via CAN and the number of the SR-CAN-modules is defined. (Number of input blocks \triangleq digital + analog input blocks).

1. Inputs/outputs

Display on the PHG

```
MP SET
P30 I/O-CONF. CAN
N.of Inp-BI.: 01
#
```

Entry in converter file

P30.CANInpNumb=1

Display on the PHG

```
MP SET
P30 I/O-CONF. CAN
N.of Out-BI.: 01
#
```

Entry in converter file

P30.CANOutNumb=1

2. Number of the SR-CAN modules

Display on the PHG

```
MP SET
P30 I/O-CONF. CAN
nmb. SrCan-moduls: 0
#
```

Entry in converter file

P30.CANSRCNumb=0

General system parameters

3. CANopen Download

Via this parameter, the drive parameter download for CANopen can be switched on or off.

- 0 = drive parameter download disabled
- 1 = drive parameter download enabled
- 2 = drive and additional parameter download enabled

For setting "2":

Machine parameter P207 REF.P. POSITION must be set with the values that are to be loaded into the axis parameters C-20B1.0. The values are not converted during the download, but adopted without changes. When setting the P207 parameter, the units that are valid in the drive (position_notation_index C-6089, position_dimension_indexC608A) must be taken into account. The entry range of the P207 parameter is +/- 999998.

Display on the PHG

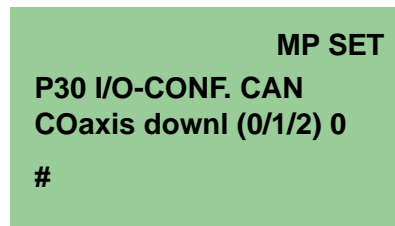

Entry in converter file

P30.CANopenDownload=0

4. Baud rate

The maximum transmission rate (baud rate) is dependent on the cable length between the rho4 and the I/O-module.

Cable length	Max. baud rate
up to 25 m	1 Mbaud (input 0)
up to 100 m	500 kbaud (input 1)
up to 200 m	250 kbaud (input 2)
up to 200 m	125 kbaud (input 3)

The maximum cable length is, corresponding to the recommendation for the Physical Layer in the CANopen Communication Profile, limited to 200 m because of a missing galvanic separation.

General system parameters

Display on the PHG

```

MP SET
P30 I/O-CONF. CAN 1
Baudrate:      0
#

```

```

MP SET
P30 I/O-CONF. CAN 2
Baudrate:      0
#

```

Entry in converter file

```

P30.Baudrate.CANBUS1=0
P30.Baudrate.CANBUS2=0
P30.Baudrate.CANBUS3=0 (only rho4.0)

```

It should be ensured that the maximum total number of possible digital I/O blocks is not exceeded.

 **The baud rate for a CAN bus may only be set unequal to 1 Mbaud if this bus is not occupied by axes.**

5. Protocol Type CANrho/CANopen

defines the protocol the CAN bus system uses.

- CANrho=0,
- CANopen=1

Display on the PHG

```

MP SET
P30 I/O-CONF. CAN 1
CANRho=0, CANopen=1 0
#

```

```

MP SET
P30 I/O-CONF. CAN 2
CANRho=0, CANopen=1 0
#

```

Entry in converter file

```

P30.ProtocolType.CANBUS1=0
P30.ProtocolType.CANBUS2=0
P30.ProtocolType.CANBUS3=0 (only rho4.0)

```

P31 Address ranges of the CAN inputs

In P31 the EA-type, address ranges, block lengths, identifiers and bus numbers for digital and analog input signals which are read via the CAN interface are defined.

 **The number of entries depends on the number of input blocks defined in P30.**

General system parameters

1. EA-Type

The EA type indicates if the input module is digital (0) or analog (1).

Display on the PHG

	MP SET
P31 ADR.CAN-I	
IOKind Block 1:	0
#	

Entry in converter file

P31.InputEAType.Block1=0

2. Start addresses

For digital input modules:

- the initial address correspond to the byte address in the PLC interface, see rho4 signal descriptions.

For analog input modules:

- this relative address indicates the situation of the data block (8 bytes) within the rho4 internal RAM area.

The setting is to be carried out as follows:

0	1stAddr Block 1
8	1stAddr Block 2
16	1stAddr Block 3
24	1stAddr Block 4
$(n-1)*8$	1stAddr Block n

In this RAM area, only analog input blocks are taken into account.

 **The adjusted RAM addresses must match the initial addresses adjusted in P405.**

Display on the PHG

	MP SET
P31 ADR.CAN-I	
1stAdr.Block 1:	208
#	

General system parameters

Entry in converter file

P31.CANInpStAdr.Block1=208

3. Block length

The block length indicates the number of bytes transferred to the corresponding input node. With a block length of < 8, the full range of a block is not fully used.

Display on the PHG

	MP SET	
P31 ADR.CAN-I		
Length Block	1:	2
#		

Entry in converter file

P31.CANInpLeng.Block1=2

4. Identifier

Address for the transfer of the telegrams onto the CAN bus.

Display on the PHG

	MP SET	
P31 ADR.CAN-I		
Ident. Block	1:	385
#		

Entry in converter file

P31.CANInpIdent.Block1=385

The identifiers to be set are described in the descriptions of the connected I/O modules. It must be ensured that no crossovers occur when the bus is occupied by axes simultaneously (see P401 and manual 'rho4 system description', chapter 6 CAN-Bus peripheral unit).

5. Bus number

Number of the CAN buses 1, 2 or 3 (only rho4.0) to which the corresponding module is connected.

General system parameters

Display on the PHG

	MP SET
P31 ADR.CAN-I	
Bus-no. Block	1: 1
#	

Entry in converter file

P31.InputCANBUS.Block1=1

6. Dss reference

For each peripheral unit (axis, transmitter, I/O module), an ASCII file may be created in which the CANopen specific parameters are set. The number contained in the name of the ASCII file must be given in the parameter Dss-Ref to create the relation between the rho4 and the ASCII file (see also chapter 3, section 3.3.4 XMP converter).

In the Bosch-Dss program, all CANopen knots are designated as 'AXIS(Index)'. The entries behind this designation apply for all CANopen knots (e.g. axes, decentral I/O modules, valves ...). Every index may be found only once.

When an Bosch-I/O module is used, default parameters are available, making a description of the transmitter objects in the ASCII file unnecessary. To make these default parameters effective, in the subparameter DssReference 0 must be entered.

Possible entries:

- 0 = Use default parameter (no ASCII-file required)
- 1 to 40 = Use parameter from corresponding ASCII file
- 1 = Switch off parameter download for corresponding module (no ASCII-file required)

Display on the PHG

	MP SET
P31 ADR.CAN-I	
DssRef Block	1: 0
#	

Entry in converter file

P31.DssRef.Block1=0

General system parameters

P32 Address ranges of the CAN outputs

In P32 the EA type, address ranges, block lengths, identifiers and bus numbers for digital and analog output signals which are read via the CAN interface are defined.

☞ **The number of entries depends on the number of output blocks defined in P30.**

1. EA type

The EA type indicates if the output module is digital (0) or analog (1).

Display on the PHG

	MP SET
P32 ADR.CAN-O	
IOKind Block	1: 0
#	

Entry in converter file

P32.OutputEAType.Block1=0

2. Start addresses

For digital output modules:

- the start address corresponds to the byte address in the PLC interface, see rho4 signal descriptions.

For analog output modules:

- this relative address gives the situation of the data block (8 bytes) within the rho4 internal RAM area.

The setting is to be carried out as follows:

0 1st.Adr. Block 1
 8 1st.Adr. Block 2
 16 1st.Adr. Block 3
 24 1st.Adr. Block 4
 (n-1)*8 1st.Adr. Block n

In this RAM area, only analog output blocks are taken into account.

☞ **The adjusted RAM addresses must match the initial addresses adjusted in P407.**

General system parameters

Byte address in PLC interface, see rho4 signal descriptions.

Display on the PHG

		MP SET
P32 ADR.CAN-O		
1st.Adr.Block	1:	208
#		

Entry in converter file

P32.CANOutStAdr.Block1=208

3. Block length

The block length indicates the number of bytes transferred to the corresponding input node. With a block length of < 8, the full range of a block is not fully used.

Display on the PHG

		MP SET
P32 ADR.CAN-O		
Length Block	1:	2
#		

Entry in converter file

P32.CANOutLeng.Block1=2

4. Identifier

Address for the transfer of the telegrams onto the CAN bus. Setting see P31.

Display on the PHG

		MP SET
P32 ADR.CAN-O		
Ident. Block	1:	513
#		

Entry in converter file

P32.CANOutIdent.Block1=513

The respective identifier numbers are described in the descriptions of the connected I/O modules.

General system parameters

5. Bus number

Number of the CAN bus, 1, 2 or 3 (only rho4.0), to which the corresponding module is connected.

Display on the PHG

		MP SET
P32 ADR.CAN-O		
Bus-no.Block	1:	1
#		

Entry in converter file

P32.OutputCANBUS.Block1=1

6. Dss reference

For each peripheral unit (axis, transmitter, I/O module), an ASCII file may be created in which the CANopen specific parameters are set. The number contained in the name of the ASCII file must be given in the parameter Dss-Ref to create the relation between the rho4 and the ASCII file (see also chapter 3, section 3.3.4 XMP converter).

In the Bosch-Dss program, all CANopen knots are designated as 'AXIS(Index)'. The entries behind this designation apply for all CANopen knots (e.g. axes, decentral I/O modules, valves ...). Every index may be found only once.

When an I/O module is used by Bosch, default parameters are available, making a description of the transmitter objects in the ASCII file unnecessary. To make these default parameters effective, in the subparameter DssReference 0 must be entered.

Possible entries:

- 0 = Use default parameter (no ASCII-file required)
- 1 to 40 = Use parameter from corresponding ASCII file
- 1 = Switch off parameter download for corresponding module (no ASCII-file required)

Display on the PHG

		MP SET
P32 ADR.CAN-O		
DssRef Block	1:	0
#		

Entry in converter file

P32.DssRef.Block1=0

General system parameters

P34 Number of characters with a set handshake

When a handshake signal of a peripheral device is set, the characters which are already in the output buffer are still put out. In machine parameter 34, the capacity of the output buffer can be reduced. The number of characters which are still put out via the corresponding interface is reduced to the set value.

- 16 16 characters (presetting)
- 1 to 15 Reduced number of characters in output buffer

Display on the PHG

```

                MP SET
P34 UART-BLOCKLENGTH
Interface 1:      16
#
```

Entry in converter file

P34.Uart0Blocklen1=16

P35 PHG mode

In P35 the PHG mode can be set.

PHG mode	Input
Mode 0, transfer rate, however, 19200 bauds	2
PHG-3 mode	1
PHG2000 mode (Transparent mode) Define/ Teach In new, otherwise mode structure	0
PHG2000 mode with user-defined mask structure	0 + PHG-display disabled

Display on the PHG

```

                MP SET
P35 PHG-MODE(1=PHG3)
PHG-Mode(0, 1, 2): =
#
```

Entry in converter file

P35.Phg3CompMode=0

General system parameters

P36 Multi-function I/O

The assignment of the digital input and output signals on the Servodyn-D drive boosters and the rho4.0 to the PLC interface is performed via machine parameter P36.

Servodyn-D:

Display on the PHG

```

MP SET
P36 MULTI FUNCT. I/O
ADDR.MF INPUT:  -1
#

```

Entry in converter file

P36.AddrMultiFuncInputs=-1

Display on the PHG

```

MP SET
P36 MULTI FUNCT. I/O
ADDR.MF OUTPUT:  -1
#

```

Entry in converter file

P36.AddrMultiFuncOutputs=-1

Address for multi-function inputs

- | | |
|------------------|--|
| 0 | Basic setting
The Servodyn-D inputs are copied onto the predefined input addresses I81.0 to I92.7 |
| 16 to 127 | Entry of the start address for the Servodyn-D inputs. The length of the necessary block is defined by the number of axes. Block length = number of axes * 4 bits |
| -1 | Disabling of the multi-function inputs. The digital inputs of the drive boosters are not copied into the PLC interface |

General system parameters

Address for multi-function outputs

- 0** Basic setting
The predefined output addresses O56.0 to O58.7 are copied onto the Servodyn-D outputs
- 16 to 127** Entry of the start address for the Servodyn-D outputs. The length of the necessary block is defined by the number of axes. Block length = number of axes * 4 bits
- 1** Disabling of the multi-function outputs. The digital outputs of the drive boosters are not served.

Example**2 kinematics**

1st kinematic	3 axes (axes 1 to 3)
2nd kinematic	5 axes (axes 4 to 8)
	Total: 8 axes

Setting of P36 Address for multifunctional inputs: 85

Assignment of the input addresses	Axis 1	In1	E85.0
		In2	E85.1
		In3	E85.2
		In4	E85.3
	Axis 2	In1	E85.4
		bis	
		In4	E85.7
	Axis 3	In1	E86.0
	.		
	Axis 4	In1	E86.4
	.		
	Axis 8	In1	E88.4
		In2	E88.5
		In3	E88.6
		In4	E88.7

General system parameters

Setting of P36 Address for multifunctional outputs: 60

Assignment of the input addresses	Axis 1	Out1	A60.0
	Axis 2	Out1	A60.1
	Axis 3	Out1	A60.2
	Axis 4	Out1	A60.3
	Axis 5	Out1	A60.4
	Axis 6	Out1	A60.5
	Axis 7	Out1	A60.6
	Axis 8	Out1	A60.7
	.		
	Axis 24	Out1	A62.7

rho4.0:**Display on the PHG**

```

MP SET
P36 MULTI FUNCT. I/O
ADDR.MF2 INPUT:  -1
#

```

Entry in converter file

```
P36.AddrMultiFunc2Inputs=-1
```

Display on the PHG

```

MP SET
P36 MULTI FUNCT. I/O
ADDR.MF2 OUTPUT: -1
#

```

Entry in converter file

```
P36.AddrMultiFunc2Outputs=-1
```

General system parameters

Address for multi-function inputs

- 0** Basic setting
The digital inputs of the rho4.0 (X21) are copied onto the available input addresses I93.0 to I94.7 (MF2INPUT01_RCO .. MF2INPUT16_RCO)
- 16 to 127** Entry of the start address from which the digital inputs of the rho4.0 (X21) are copied.
- 1** Disabling of the multi-function outputs. The digital outputs of the rho4.0 (X21) are not copied into the PCL interface.

Address for multi-function outputs

- 0** Basic setting
The available output addresses O52.0 to O52.7 are copied onto the digital outputs of the rho4.0 (X11) (MF2OUT01_RCI .. MF2OUT08_RCI)
- 16 to 127** Entry of the start address of the digital outputs of the rho4.0 (X11) in PCL interface (O16.0 to O127.7)
- 1** Disabling of the multi-function outputs of the rho4.0 (X11). The digital outputs of the rho4.0 are not served from the PCL.
This setting is necessary when the digital outputs of the rho4.0 in BAPS programs are served in BAPS programs (rapid outputs).

P37 Electronic type plate

In parameter P37 the input and output identifiers of the Read/Write services are entered. These identifiers are necessary for the Read/Write of the machine parameters and the serial number. The CAN bus number of the respective module is also indicated.

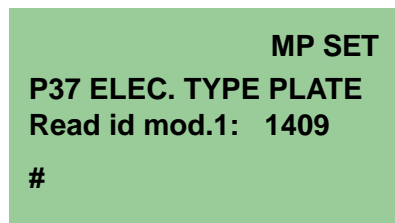
1. Input of Read identifier**Display on the PHG****Entry in converter file**

P37.SRCANInpIdent.Block1=1409

General system parameters

2. Input of Write identifier

Display on the PHG

```
MP SET
P37 ELEC. TYPE PLATE
Write id mod.1: 1537
#
```

Entry in converter file

P37.SRCANOutIdent.Block1=1537

The identifiers can be found in the description of the SR-CAN module in the manual 'rho4 System description', chapter 6 CAN-Bus peripherals.

3. CAN bus number

Display on the PHG

```
MP SET
P37 ELEC. TYPE PLATE
Bus-nb. modul.1: 1
#
```

Entry in converter file

P37.SRCANBUSNum.Block1=1

P38 Sercos-Interface

Sercos drive parameter download

1. Baud rate

Display on the PHG

```
MP SET
P38 SERCOS-INTERFACE
Baud-Rate [MBaud] 2
#
```

Entry in converter file

P38.SERCOSBaudrate=2

General system parameters

2. Download

Defines if, when the rho4 is started, the saved drive parameters are downloaded to the drive.

Entry:

- 0: switch off download
- 1: carry out download

Display on the PHG

```

MP SET
P38 SERCOS-INTERFACE
Par-Download (0/1)  0
#

```

Entry in converter file

P38.SERCOSDownload=0

P39 Workspace monitoring

With this parameter, it is possible to program the max. 32 locked workspaces.

For each workspace, 7 values are entered:

Kin-No	Number of the allocated kinematic
Xmin	smallest X-coordinate of the workspace
Xmax	highest X-coordinate of the workspace
Ymin	smallest Y-coordinate of the workspace
Ymax	highest Y-coordinate of the workspace
Zmin	smallest Z-coordinate of the workspace
Zmax	highest Z-coordinate of the workspace

Authorized value ranges:

Kin-No	: integral values from 0 to 16 Kin-No = 0 means that the monitoring for the defined workspace is inactive.
Min-/Max. values	: real numbers with value range –999999.00 to +999999.00. The limit values describe locked workspaces (cuboids) with the unit [mm] in fixed space coordinate system of the kinematic allocated through 'Kin-No'.

General system parameters

Display on the PHG

	MP SET
P39 WORKSPACE	1
Kin-No: 1	
#	

Entry in converter file

P39.KinNo.Workspace1=1

Display on the PHG

	MP SET
P39 WORKSPACE	1
Xmin:	-500.00
#	

Entry in converter file

P39.Xmin.Workspace1=-500.00

Display on the PHG

	MP SET
P39 WORKSPACE	1
Xmax:	-0.10
#	

Entry in converter file

P39.Xmax.Workspace1=-0.10

Display on the PHG

	MP SET
P39 WORKSPACE	1
Ymin:	-200.00
#	

Entry in converter file

P39.Ymin.Workspace1=-200.00

General system parameters

Display on the PHG

```
MP SET
P39 WORKSPACE 1
Ymax: 200.00
#
```

Entry in converter file

P39.Ymax.Workspace1=200.00

Display on the PHG

```
MP SET
P39 WORKSPACE 1
Zmin: -500.00
#
```

Entry in converter file

P39.Zmin.Workspace1=-500.00

Display on the PHG

```
MP SET
P39 WORKSPACE 1
Zmax.: 100.00
#
```

Entry in converter file

P39.Zmax.Workspace1=100.00

Speeds

5 Speeds

Group 100	Speeds
P101	Nominal lag
P102	Maximum path speed
P103	Maximum axis speed PTP
P104	Maximum slope acceleration PTP
P105	Slope point PTP in machine coordinates JC
P106	Slope point in path mode
P107	Slope point Jog in world coordinates WC
P108	Referencing speed
P109	First reduced referencing speed
P110	Second reduced referencing speed
P111	Jog speed WC slow
P112	Jog speed WC fast
P113	Jog speed JC slow
P114	Jog speed JC fast
P115	Incremental steps WC
P116	Incremental steps JC
P117	A/D slope-accel. jog WC
P118	Range AFACTOR/DFACTOR
P119	Range VFACTOR
P120	On-status slope mode
P121	Form of acceleration
P122	Acceleration/deceleration change times PTP in JC
P123	Acceleration/deceleration change times Jog in WC
P124	Acceleration/deceleration change times in path operation
P125	Switch-off time for interpolator stop
P126	Switch-off time for standstill monitoring
P127	Inpos range for standstill monitoring
P128	A/D slope Jog in JC
P129	Slope point Jog in JC
P130	A/D change times for Jog JC

 These machine parameters are to be entered for each kinematic.

Speeds

P101 Nominal lag

With P101 the nominal lag which is reached at maximum axis speed (nominal speed) is entered.

The input is made in degrees resp. in mm.

The value in P101 is used only for interpolator stop monitoring and servo error monitoring. It does not have any effect on the control behavior. The values must be adjusted according to the control loops of the drive modules.

With a wrong setting, Interpolator stop monitoring and Servo error monitoring will not function.

Value too low: Monitoring responds too early

Value too high: Monitoring responds too late or not at all. This can cause that in the drive module, a very big lag is accumulated which is only slowly reduced at the end of a movement.

Setting specification:

$$L_N [\text{degrees}] = V_{\max} [\text{degrees/s}] / K_V [1/\text{s}] + \text{offset} [\text{degrees}]$$

L_N : Lag

V_{\max} : Maximum axis speed (P103)

K_V : Position controller gain (Servodyn-GC: position loop gain)

Offset: $V_{\max} [\text{degrees/s}] * \text{deceleration change time} [\text{ms}]/1000$

deceleration change
time:

Servodyn-GC: $t_{\text{clock}} [\text{ms}] + 6 [\text{ms}]$

Servodyn-D-CANrho: $2 * t_{\text{clock}} [\text{ms}] + 7 [\text{ms}]$

Servodyn-D-CANopen: $5 * t_{\text{clock}} [\text{ms}]$

Servodyn-D-SERCOS: $5 * t_{\text{clock}} [\text{ms}]$

Speeds

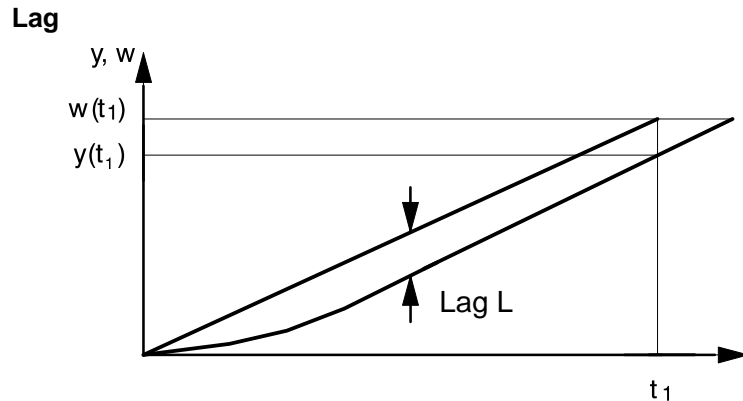

By input of the nominal lag, the Interpolator stop ranges and the Servo error ranges are defined.

- Input range between 0.01 and 100000.
- The maximum lag is 130 % of the nominal lag.
- If the maximum lag is exceeded, a Servo error occurs.
- At 110.5 % of the nominal lag, an interpolator stop occurs.

Display on the PHG

```

ROBI_1      MP SET
P101 NOMINAL LAG
A01      66.000
#

```

Entry in converter file

P101.NomLag.Kin1.Axis1=66.000

P102 Maximum path speed

Maximum programmable travel speed in world coordinates (WC) at the Tool Center Point (TCP). The input is made in mm/s.

The definition of a sensible maximum path speed depends on the resolution of the measuring system, the minimum programmed point spacing, the mechanical components of the robot and the sampling time of the servo loop (clock start time).

Display on the PHG

```

ROBI_1      MP SET
P102 MAX. PATH SPEED
          1500.00
#

```

Speeds

Entry in converter file

P102.MaxPathSpeed.Kin1=1500.00

P103 Maximum axis speed PTP

Maximum travel speed of the individual machine axes (machine coordinates JC), restricted by the drive power. The input is made in degrees resp. mm/s.

For Servodyn-GC drives

$$\text{Input value} \leq \frac{\text{max. RPM (automatic mode) [rev/min]} * \text{CPS}}{60 * \text{MS-factor [incr/degrees resp. incr/mm]}}$$

Max. RPM (automatic mode): Drive parameters (see Servodyn-GC description)

CPS: Can position scaling (see Servodyn-GC description)

MS-factor: see P401

 **If a higher speed is preset by the rho4 than the maximum speed set at the Servodyn-GC, an interpolator stop will be released by the Servodyn-GC.**

Display on the PHG

```

ROBI_1      MP SET
P103 MAX. AXIS SPEED
A01        50.000
#

```

Entry in converter file

P103.MaxPtpSpeed.Kin1.Axis1=50.000

Speeds

P104 Maximum slope acceleration PTP

Acceleration of the individual axes for PTP movement in automatic mode. Input range: 0.01 to 999999,99 degrees/s² resp. mm/s².

Standard value: P104 = 10 * P103, i.e. the axis reaches its maximum speed after 100 ms.

The values entered under P104 are additionally used for monitoring the axis acceleration in path mode.

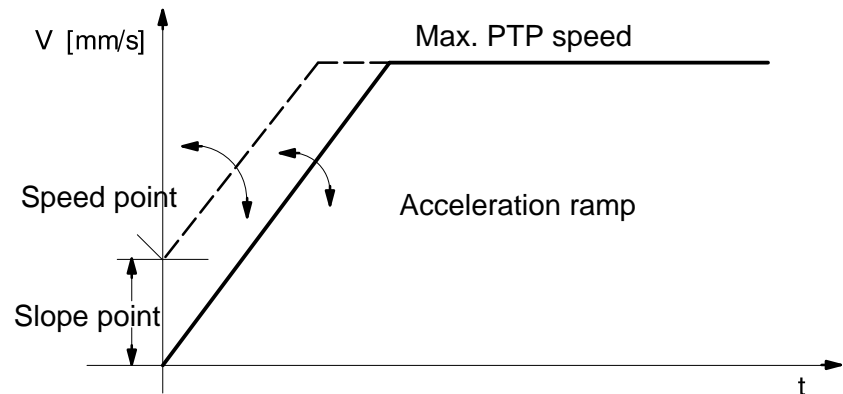
**Display on the PHG**

```

ROBI_1      MP SET
P104 SLOPE-ACCEL.PTP
A01        9999.00
#

```

Entry in converter file

P104.AcclPtp.Kin1.Axis1=9999.00

Speeds

P105 Slope point PTP in machine coordinates JC

The slope acceleration acts starting with the speed point, see illustration P104. Below, the speed default is performed in jumps. The input is made in degrees/s resp. mm/s.

When running without slope, i.e. with a default value in jumps, the slope point is set to the maximum speed.

The setpoint default in form of a ramp also acts with low speeds. For that, the slope point must be preset to 0.

Display on the PHG

```
ROBI_1      MP SET
P105 SLOPE-PNT PTP JC
A01        2000.00
#
```

Entry in converter file

P105.SloPointPtp.Kin1.Axis1=2000.00

P106 Slope point, path operation

The programmed path-slope-acceleration acts starting with the path speed point. The input is made in mm/s.

When running without slope, the slope point is set to the maximum path speed.

The slope point must be declared separately for program slope and block slope.

Display on the PHG

```
ROBI_1      MP SET
P106 PATH-SLOP.POINT
Inst        0.000
#
```

Entry in converter file

P106.SlpPathBlock.Kin1=0.000

Speeds

Display on the PHG

ROBI_1	MP SET
P106 PATH-SLOP.POINT	
Prog	0.000
#	

Entry in converter file

P106.SlpPathProg.Kin1= 0.000

P107 Slope point Jog in world coordinates WC

When the Jog path speed is reached, the WC slope acceleration acts which is set in P117. Below, the speed change is performed in jumps. When running without slope, the slope point is set to the maximum WC Jog speed.

The input is made for world coordinates.

Display on the PHG

ROBI_1	MP SET
P107 SLOP-PNT JOG WC	
K01	2000.00
#	

Entry in converter file

P107.SloPointWc.Kin1.Coord1= 2000.00

P108 Referencing speed

With P108 the referencing speed is defined (acts only if the reference points have already been approached).

The entered values must not be higher than the values in parameter P103, referring to the same axis each. The standard value is 10% of P103.

For Servodyn-GC-drives

$$\text{Input value} \leq \frac{\text{max. RPM (Manual mode) [rev/min]} * \text{CPS}}{60 * \text{MS conv. factor [incr/degree resp. incr/mm]}}$$

Speeds

- max. RPM (Manual mode): Drive parameters (see Servodyn-GC description)
- CPS: Can Position Scaling (see Servodyn-GC-description)
- MS conv. factor: see P401

☞ If a higher speed than the maximum speed set at the Servodyn-GC is preset by the rho4, an interpolator stop will be released by the Servodyn-GC.

Display on the PHG

```

ROBI_1      MP SET
P108 REFERENC. SPEED
A01      10.000
#
    
```

Entry in converter file

P108.RefSpeed.Kin1.Axis1= 10.000

Referencing (speed profile)

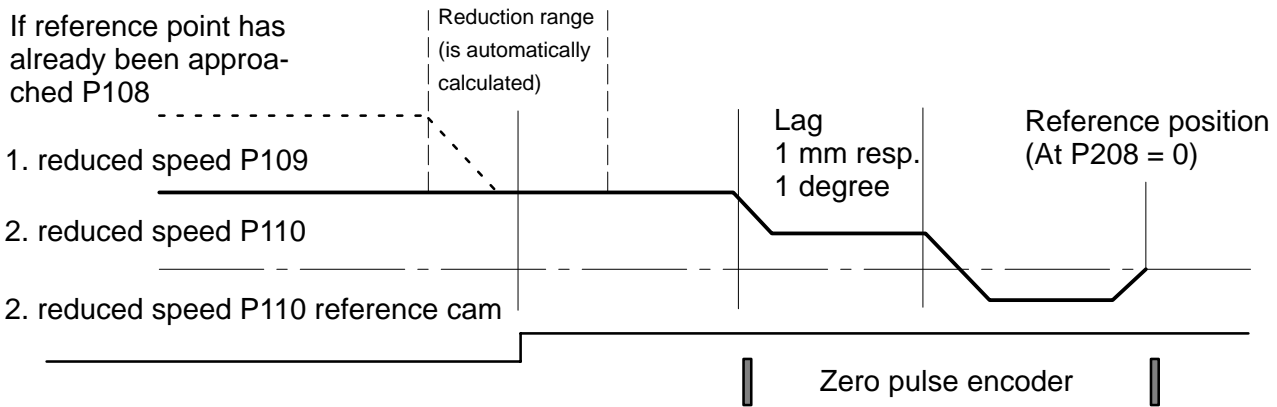

The selected axis moves into the direction of the reference point with the direction indicated in P402 and with the speed defined in P109. After having recognized the reference cam, edge selection in P403, the axis moves on until the first zero pulse. There the actual value of the reference point is taken over by P207. The axis decelerates to the second reduced speed moves on for 1 mm resp. 1 degree. Finally, the position defined in P208 is approached.

Speeds

If referencing is selected while the axis is standing on the reference cam, the reference cam is left at first in opposite direction. Only then, the referencing run described above, is carried out.

The switching edge of the reference cam should be detected in the middle between two zero pulses. Thereby, error-detections are avoided.

In P208 the reference point offset is defined. It is always approached with a direction reversing for the compensation of the spindle play.

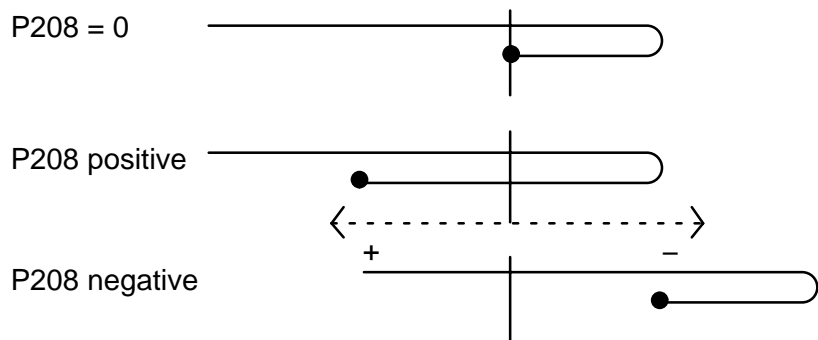
Reversing play compensation**P109 First reduced referencing speed**

 **The values must not be higher than the values in the parameter blocks P103 and P108. Standard value: 5 % of P103.**

With this speed it is travelled to the marker of the incremental MS for the first time.

With P109 the first reduced speed is defined which becomes active when the software reduction switch is reached. The input is made in degrees/s resp. mm/s.

Maximum input values for CAN-axes, see P108

Display on the PHG

```

ROBI_1      MP SET
P109 1.RED.REF.SPEED
A01      10.000
#

```

Entry in converter file

P109.RefSpeed1Red.Kin1.Axis1= 10.000

Speeds

P110 Second reduced referencing speed

 The values must not be higher than the values defined in parameter block P109. Standard value: 2 % of P103.

With P110 the second reduced speed is defined with which the synchronization to the zero pulse is effected. The input is made in degrees/s resp. mm/s.

Maximum input values for CAN-axes, see P108.

Display on the PHG

```
ROBI_1      MP SET
P110 2.RED.REF.SPEED
A01         4.000
#
```

Entry in converter file

P110.RefSpeed2Red.Kin1.Axis1=4.000

P111 Jog speed WC slow

The speed refers to the path of the TCP in world. The input is made in mm/s.

The PHG switches over to the fast Jog speed after approximately 2 seconds if the Jog key is continually pressed.

The input should be below the value of manual feed WC fast (P112).

Display on the PHG

```
ROBI_1      MP SET
P111 J.SPEED WC SLOW
K01         5.000
#
```

Entry in converter file

P111.JogSpWcSlow.Kin1.Coord1=5.000

Speeds

P112 Jog speed WC fast

The speed refers to the path of the Tool Center Point (TCP) in world. The input is made in mm/s.

The input should be above the value of Jog speed WC slow.

Display on the PHG

```

ROBI_1      MP SET
P111 J.SPEED WC FAST
K01        25.000
#

```

Entry in converter file

P112.JogSpWcFast.Kin1.Coord1=25.000

The automatic switch-over by a short actuation of the Jog key between 'incremental movement' and slow resp. fast continuous movement (after two seconds) can be disabled with the interface signal 'external speed selection for manual'.

If this signal = 1 the interface inputs (ct. No. 144 to 147) are valid for the speed selection:

- Manual feed, slow: step dimension, small
- Manual feed, fast: step dimension, large

P113 Jog speed JC slow

Axis speeds in connection with the PHG. The input is made in degrees/s resp. mm/s.

The PHG switches over to the fast Jog speed after approximately two seconds if the Jog key is continually pressed. The input should be below the value of 'Jog speed JC fast' from P114. Standard value: 5 % of P103.

Maximum input values for CAN-axes, see P108

Display on the PHG

```

ROBI_1      MP SET
P111 J.SPEED WC SLOW
A01        3.000
#

```

Entry in converter file

P113.JogSpJcSlow.Kin1.Axis1=3.000

Speeds

P114 Jog speed JC fast

Axis speeds in connection with the PHG. The input is made in degrees/s resp. mm/s.

The input should be above the value of the 'Jog speed JC slow' from P113. Standard value: 10 % of P103.

Maximum input values for CAN-axes, see P108

Display on the PHG

```
ROBI_1      MP SET
P111 J.SPEED JC FAST
A01         15.000
#
```

Entry in converter file

P114.JogSpJcFast.Kin1.Axis1=15.000

P115 Incremental steps WC

Input of two different step dimensions for a movement with the PHG in world coordinates. The input range is between 0.001 and 1000.0 mm.

Input value 0 is not allowed.

Display on the PHG

```
ROBI_1      MP SET
P115 INCREM.STEPS WC
1           1.000
#
```

Entry in converter file

P115.IncStWcSmall.Kin1=1.000

Display on the PHG

```
ROBI_1      MP SET
P115 INCREM.STEPS WC
2           10.000
#
```

Speeds

Entry in converter file

P115.IncStWcLarge.Kin1=10.000

P116 Incremental steps JC

Input of two different step dimensions for a movement with the PHG in machine coordinates. The input range is between 0.001 and 1000.0 mm. The input is made in degrees resp. mm.

Input value 0 is not allowed.

Display on the PHG

ROBI_1	MP SET
P116 INCREM.STEPS JC	
1	0.500
#	

Entry in converter file

P116.IncStJcSmall.Kin1=0.500

Display on the PHG

ROBI_1	MP SET
P116 INCREM.STEPS JC	
2	5.000
#	

Entry in converter file

P116.IncStJcLarge.Kin1=5.000

P117 A/D slope accel. Jog WC

With P117 the slope acceleration resp. deceleration in the individual coordinates in Jog mode is defined in WC.

The acceleration resp. deceleration refers to the path of the Tool Center Point in space.

The input range is between 0.01 and 999999.99 mm/s². Display on the PHG

Speeds

ROBI_1	MP SET
P117 A-SLOPE JOG WC	
K01	1000.00
#	

ROBI_1	MP SET
P117 D-SLOPE JOG WC	
K01	1000.00
#	

Entry in converter file

P117.ASlopeJogWc.Kin1.Coord1=1000.00

P117.DSlopeJogWc.Kin1.Coord1=1000.00

P118 AFACTOR/DFACTOR range

With P118 the input range for the acceleration resp. deceleration factor is defined.

The input range is between 0.0001 and 9.9999.

The AFACTOR and DFACTOR can be programmed in BAPS and can be set in the operating mode help functions (Mode 11.x).

With the DFACTOR the deceleration phase of a movement can be influenced.

The DFACTOR operates in the same way as the AFACTOR.

$$A_{act} = A * AFACTOR$$

$$D_{act} = A * DFACTOR$$

AFACTOR and DFACTOR are preset with 1.

Display on the PHG

ROBI_1	MP SET
P118 AFACTOR/DFACTOR	
minimumAFA	0.0001
#	

ROBI_1	MP SET
P118 AFACTOR/DFACTOR	
maximumAFA	9.9999
#	

Entry in converter file

P118.RangeAfaMin.Kin1=0.0001

P118.RangeAfaMax.Kin1=9.9999

Speeds

Display on the PHG

ROBI_1	MP SET
P118 AFACTOR/DFACTOR	
minimumDFA	0.0001
#	

ROBI_1	MP SET
P118 AFACTOR/DFACTOR	
maximumDFA	9.9999
#	

Entry in converter file

P118.RangeDfaMin.Kin1=0.0001
P118.RangeDfaMax.Kin1=9.9999

P119 VFACTOR range

With P119 the input range for the speed factor is defined.

The input range is between 0.0001 and 9.9999.

The VFACTOR can be programmed in BAPS and can be set in the operating mode help functions (Mode 11.x).

$$V_{act} = V_{BAPS} * P119_{VFACTOR\ Kin.dep.} * P23_{VFACTOR\ global} * V_{PHG/interf.}$$

Display on the PHG

ROBI_1	MP SET
P119 RANGE OF VFACT	
minimum	0.0001
#	

ROBI_1	MP SET
P119 RANGE OF VFACT	
minimum	3.3333
#	

Entry in converter file

P119.RangeVfaMin.Kin1=0.0001
P119.RangeVfaMax.Kin1=3.3333

P120 ON condition of slope mode

It is defined by P120 which slope mode (BLOCK_SLOPE or PROGR_SLOPE) is automatically active if in the BAPS program no slope mode has been programmed.

The ON condition is overwritten in the BAPS program by programming the BLOCK_SLOPE or PROGR_SLOPE.

- BLOCK_SLOPE = 0
- PROGR_SLOPE = 1

Speeds

Display on the PHG

ROBI_1	MP SET
P120 SLOPE-SEL IS/PR	
(0/1)	0
#	

Entry in converter file

P120.SlopeMode.Kin1=0

P121 Acceleration form

With P121 it is possible to select between

- Ramp or
- \sin^2 -similar.
- Slope form RA/SI (0 = ramp; 1 = \sin^2 -similar).

Ramp means previous acceleration form, \sin^2 stands for soft start with a \sin^2 -similar acceleration and deceleration form.

Display on the PHG

ROBI_1	MP SET
P121 SLOPEFORM RA/SI	
(0/1)	0
#	

Entry in converter file

P121.SlopeForm.Kin1=0

Note on block slope and soft start (\sin^2 -similar)

In order to achieve a jerk-free acceleration or deceleration of axes of a robot or a handling system, the speed change at the start and at the end of a movement is influenced so that no jump occurs neither with the speed nor with the acceleration.

The speed increase and decrease is there composed of square and linear sections.

Functional description

The axis movement is started with $v = 0$ (speed) and $a = 0$ (acceleration). three acceleration phases are run through in order to reach the setpoint speed.

- Phase 1 Linear acceleration increase up to the maximum acceleration

Speeds

- Phase 2 Constant acceleration
- Phase 3 Linear acceleration reduction to zero

The gradient of the acceleration ramp is the same in phase 1 and 3.

The constant phase (phase 2) of the acceleration procedure is calculated in a way that at the end of phase 3 the programmed setpoint speed is reached.

Deceleration is analog to acceleration.

In automatic mode it is possible to set the maximum deceleration separately from the maximum acceleration. For this purpose, the BAPS language element DFACTOR was introduced analog to the language element AFACTOR.

The maximum acceleration values are defined for manual mode with P104 and P117, in automatic mode with P104 for PTP as well as for the programmed A-value for LINEAR.

The \sin^2 -similar acceleration behaviour acts in all operating modes.

- Manual mode: JC; WC
- Automatic: PTP, LINEAR, CIRCULAR.

The basic relationship between acceleration and speed is shown in the following diagram.

Speeds

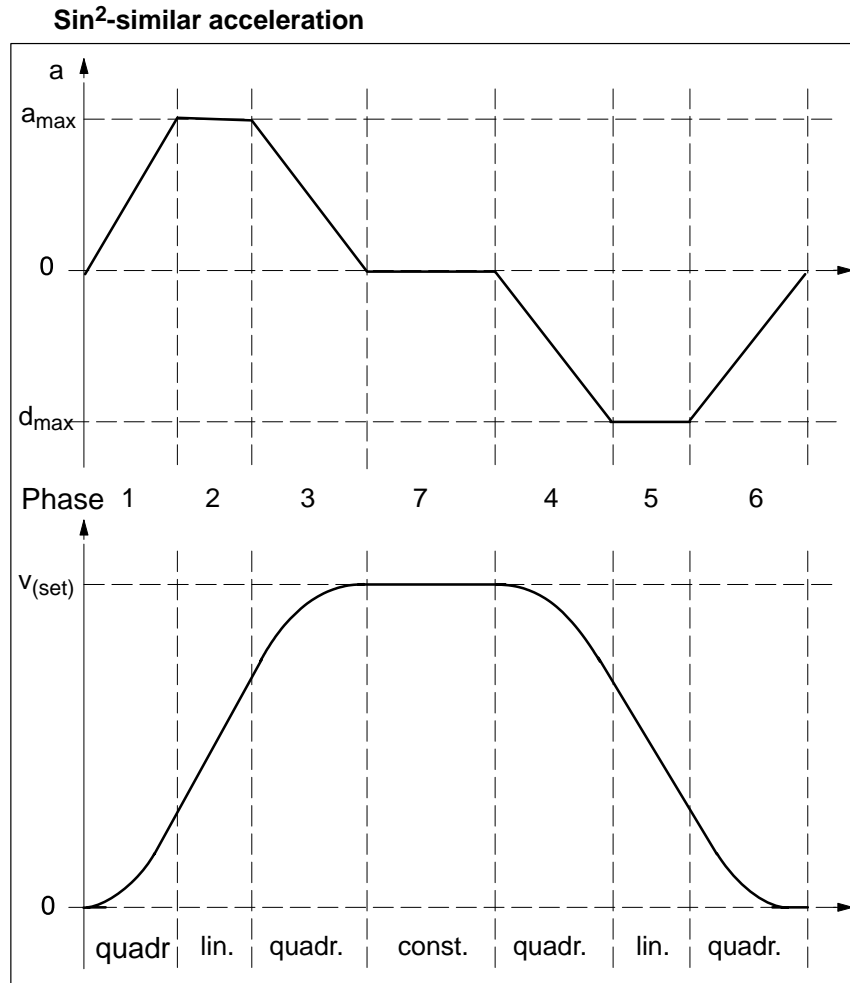

Phase 1 and 3, resp. 4 and 6, i.e. the quadratic ranges are of equal length. Their duration can be defined in milliseconds by P122 (PTP and JOG JC), P123 (Jog WC) and P124 (path mode).

The duration of phases 2 and 5 depends on the programmed speed and on the programmed distance. It is calculated by the RC.

 **If the sin²-similar slope function is used, the time response of the handling system, compared to the previous ramp slopes, changes.**

With unchanged acceleration values, the time requirement for acceleration and deceleration processes increases.

The same time response can be achieved by increasing the acceleration values. It must, however, be checked whether the drives can withstand these higher acceleration values.

Speeds

Constant acceleration (ramp slope)

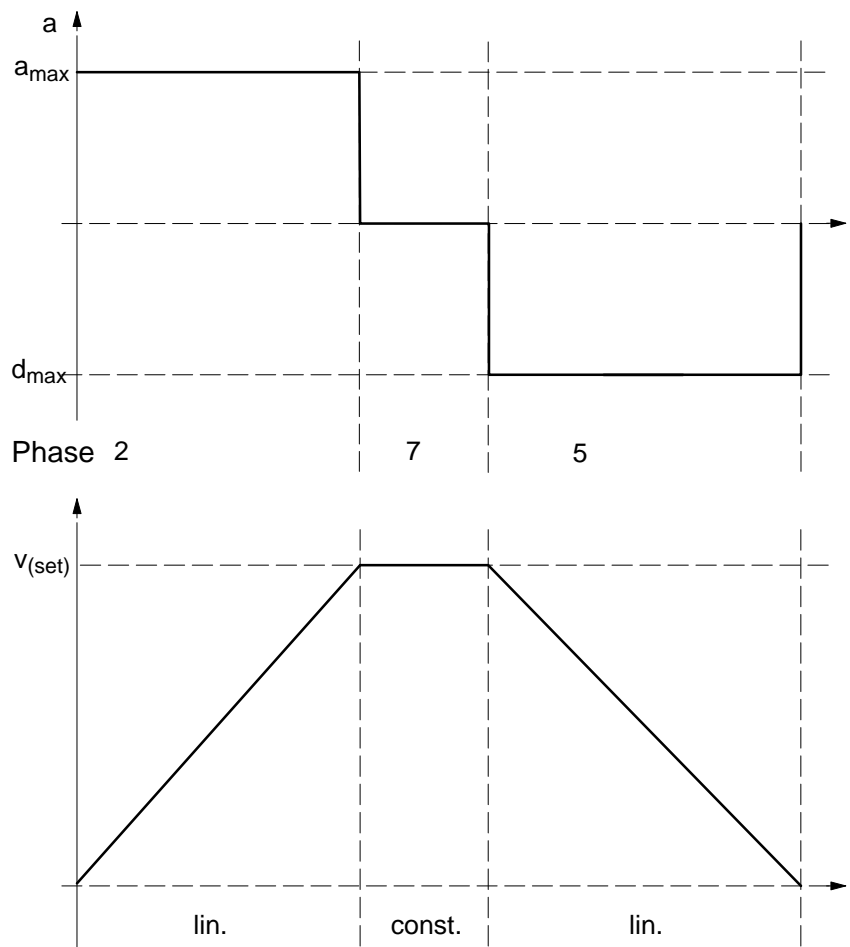

Speeds

P122 Acceleration/deceleration change times PTP in JC

The acceleration/deceleration change times for PTP movements in JC. For each axis two values must be entered. The input is made in ms.

- Time until maximum acceleration is reached
- Time until maximum deceleration is reached

 **Parameter P122 is of significance only for a sin²-similar slope form as the acceleration is otherwise constant.**

Display on the PHG

ROBI_1	MP SET
P122 A- VAR-TIME PTP	
A01	100.00
#	

ROBI_1	MP SET
P122 D- VAR-TIME PTP	
A01	100.00
#	

Entry in converter file

P122.ATimePtpJc.Kin1.Axis1=100.00
P122.DTimePtpJc.Kin1.Axis1=100.00

P123 Acceleration/deceleration change times Jog in WC

Acceleration/deceleration change times for manual travel in world coordinates (WC). The input is made in ms.

For each axis two values must be entered.

- Time until maximum acceleration is reached
- Time until maximum deceleration is reached

Display on the PHG

ROBI_1	MP SET
P123 A- VAR-TIME WC	
K01	100.00
#	

ROBI_1	MP SET
P123 D- VAR-TIME WC	
K01	100.00
#	

Entry in converter file

P123.ATimeJogWc.Kin1.Coord1=100.000
P123.DTimeJogWc.Kin1.Coord1=100.000

 **P123 is of significance only for a sin²-similar slope form as the acceleration is otherwise constant.**

Speeds

P124 Acceleration/deceleration change times in path mode

Acceleration/deceleration change times in path operation (LINEAR, CIRCULAR). For each axis two values must be entered. The input is made in ms.

- Time until maximum acceleration is reached
- Time until maximum deceleration is reached

The entered values apply to the rising and falling acceleration resp. deceleration edges each.

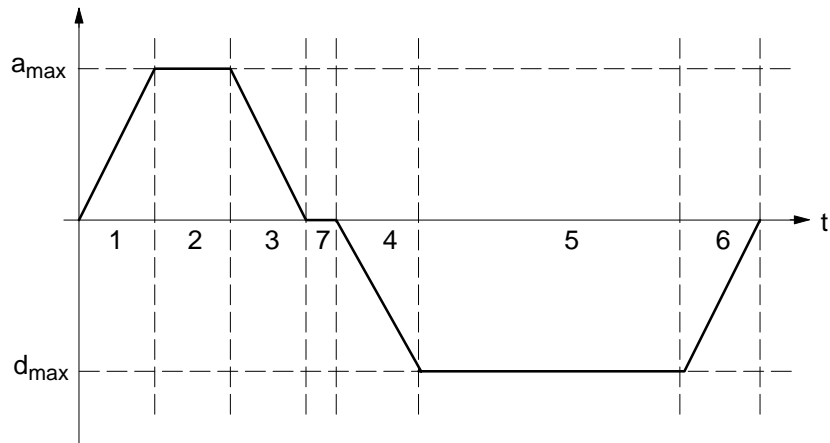

Phase 1 and 3, resp. 4 and 6 are always of the same length.

☞ **The resulting acceleration/deceleration time with respect to the speed is made up of twice the time specified in P122 or P123, resp. P124 (acceleration/deceleration change times) and the time of constant acceleration.**

Resulting acceleration time = phase 1 + phase 2 + phase 3

Resulting deceleration time = phase 4 + phase 5 + phase 6

Display on the PHG

ROBI_1	MP SET
P124 A/D VAR-TIME PA	
A	100.000
#	

ROBI_1	MP SET
P124 A/D VAR-TIME PA	
D	100.000
#	

Entry in converter file

P124.ATimeJogPath.Kin1=100.000

P124.DTimeJogPath.Kin1=100.000

☞ **P124 is of significance only for a sin²-similar slope form as the acceleration is otherwise constant.**

Speeds

P125 Switch-off time for interpolator stop

Maximum permissible time per axis during which the interpolator stop condition (setpoint value > 110%) may exist. If this time is exceeded the signal Ready2 is cancelled for safety reasons and Emergency Stop is triggered.

- Number of parameters: 1 value per axis
- Permissible values: -1 to 2000 ms

Input = -1 or 0: Switch off monitoring (for test purposes only)

Display on the PHG

```
ROBI_1      MP SET
P125 SWO.T. IPO-STOP
A01         2000 ms
#
```

Entry in converter file

P125.SwOffTimeIpo.Kin1.Axis1=2000

P126 Switch-off time for standstill monitoring

Time between the leaving of the set position range and the release of the error turn-off at standstill of the robot. Maximum permissible time between termination of the interpolation and reaching of the set position range.

- Number of parameters: 1 value per axis
- Permissible values: -1 to 2000 ms

Input = -1 or 0: Switch off monitoring (for test purposes only)

Display on the PHG

```
ROBI_1      MP SET
P126 SWO.T. STANDST
A01         2000 ms
#
```

Entry in converter file

P126.SwOffTimeSta.Kin1.Axis1=2000

Speeds

P127 Inpos range for standstill monitoring

Maximum permissible deviation of the actual position from the setpoint position for standstill monitoring. The input is made in mm resp. degrees.

Setpoint position range = setpoint position \pm input value.

- Number of parameters: 1 value per axis
- Permissible values: 0 to 10

Display on the PHG

```

ROBI_1      MP SET
P127 IN POS STANDST.
A01        10.000
#

```

Entry in converter file

P127.InPosStStill.Kin1.Axis1=10.000

P128 A/D-slope Jog in JC

Acceleration of the individual axes in manual mode.

The input is made in degrees/s², resp. mm/s², standard value: 100 % of P104.

Display on the PHG

```

ROBI_1      MP SET
P128 A- SLOPE JOG JC
A01        9999.0
#

```

```

ROBI_1      MP SET
P128 D- SLOPE JOG JC
A01        9999.00
#

```

Entry in converter file

P128.ASlopeJogJc.Kin1.Axis1=9999.00

P128.DSlopeJogJc.Kin1.Axis1=9999.00

Speeds

P129 Slope point Jog in JC

Speed defaults below the slope point are put out in form of jumps. Above the slope point, the slope acceleration from slope P128 is active.

The input is made in degrees/s, resp. mm/s.

If operation without slope is desired the slope point is set to the maximum speed.

Display on the PHG

```

ROBI_1      MP SET
P129 SLOP-PNT JOG JC
A01         2000.0
#

```

Entry in converter file

P129.SloPointJog.Kin1.Axis1=2000.00

P130 A/D change times for Jog JC

Acceleration/deceleration change times for manual travel in JC. For each axis, two values must be entered. The input is made in ms.

- Time until maximum acceleration is reached
- Time until maximum deceleration is reached

Display on the PHG

```

ROBI_1      MP SET
P130 A- VAR-TIME JOG
A01         100.000
#

```

```

ROBI_1      MP SET
P130 D- VAR-TIME JOG
A01         100.000
#

```

Entry in converter file

P130.ATimeJogJc.Kin1.Axis1=100.000

P130.DTimeJogJc.Kin1.Axis1=100.000

 **P130 is of significance only for a sin2-similar slope form as the acceleration is otherwise constant.**

Speeds

5.1 Notes on the speed parameters

In P121 the acceleration form is defined.

Two acceleration forms are available:

- 0: Ramp slope
- 1: \sin^2 -slope

For ramp slope the following parameters are valid for the travel of axes:

5.1.1 Axis travel in PTP (Point to point)

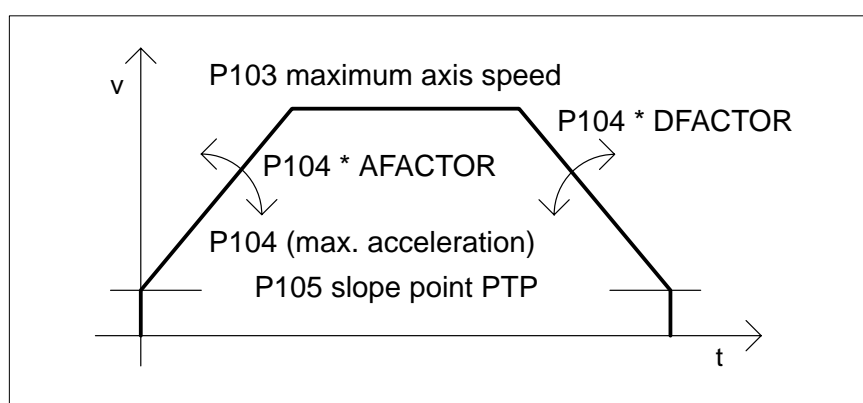

AFACTOR = **AFACTOR**_{BAPS} (dep.on P118) * **AFACTOR**_{PHG/interf.} (dep.on P22)

DFACTOR = **DFACTOR**_{BAPS} (dep.on P118) * **DFACTOR**_{PHG/interf.} (dep.on P22)

Normally, the slope point is set to 0. The PTP movement does not start with a setpoint jump of the height which is defined in P105 but starts linear from speed 0. It is then accelerated to maximum speed (P103) with the acceleration value set in P104. Deceleration is performed again with the value set in P104. The parameters are to be set axis-specifically.

Speeds

5.1.2 Axis travel in path operation (LINEAR, CIRCULAR)

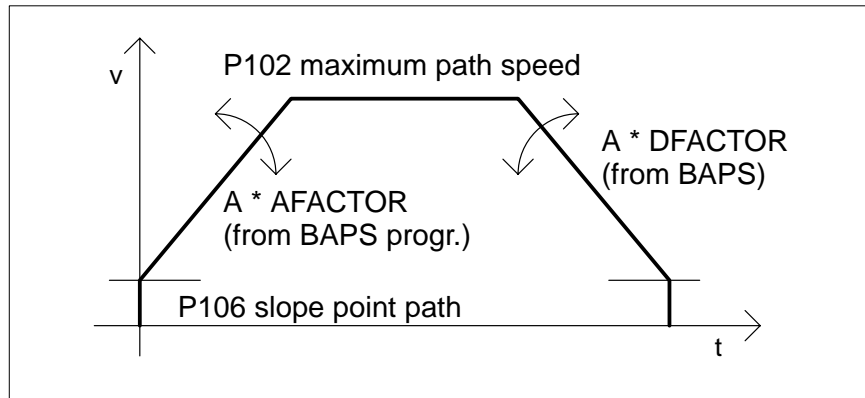

With path-controlled movements, the parameterization of the speed and the acceleration refers to the Tool Center Point (TCP).

Contrary to the PTP-movement, the setting of the maximum speed is not performed by machine parameters but in the user program with A (acceleration) and V (velocity).

5.1.3 Manual travel of the axes in WC

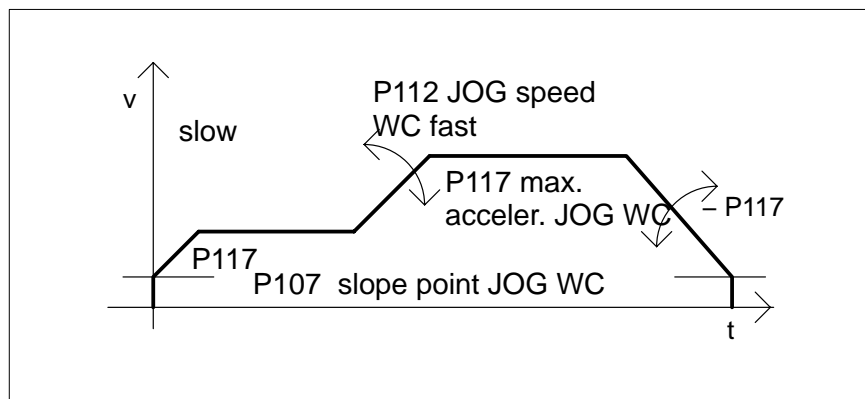

With manual movement, only the value entered in P115 is travelled when shortly actuating the axis key in WC.

If the axis key remains pressed, the axis is accelerated to the slow Jog speed set in P111.

If the axis key remains pressed for more than two seconds, the axis is accelerated to the fast Jog speed set in P112.

If the system is to be accelerated in a smoother way, it is possible to set a \sin^2 -acceleration with machine parameter P121 = 1.

Speeds

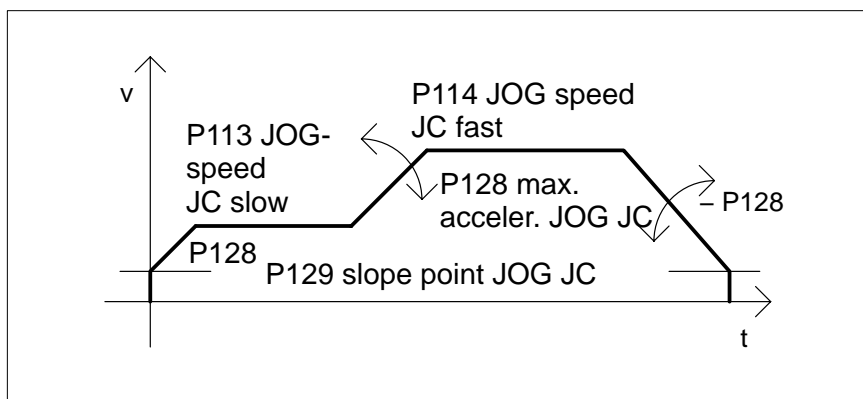
5.1.4 Manual travel of the axes in JC

With manual movement, only the value entered in P116 is travelled when shortly actuating the axis key in JC.

If the axis key remains pressed the axis is accelerated to the slow Jog speed set in P113.

If the axis key remains pressed for more than two seconds, the axis is accelerated to the fast Jog speed set in P114.

If the system is to be accelerated in a smoother way, it is possible to set a \sin^2 -acceleration with machine parameter P121 = 1.

The times for the acceleration and the deceleration in the different travel modes are defined in the following parameters:

- P122 Automatic travel in PTP
- P124 Automatic path travel (LINEAR, CIRCULAR)
- P123 Manual travel (Jog) in WC
- P130 Manual travel (Jog) in JC

These parameters must only be entered if 1 has been entered in P121.

Speeds

5.1.5 Acceleration/deceleration change times PTP

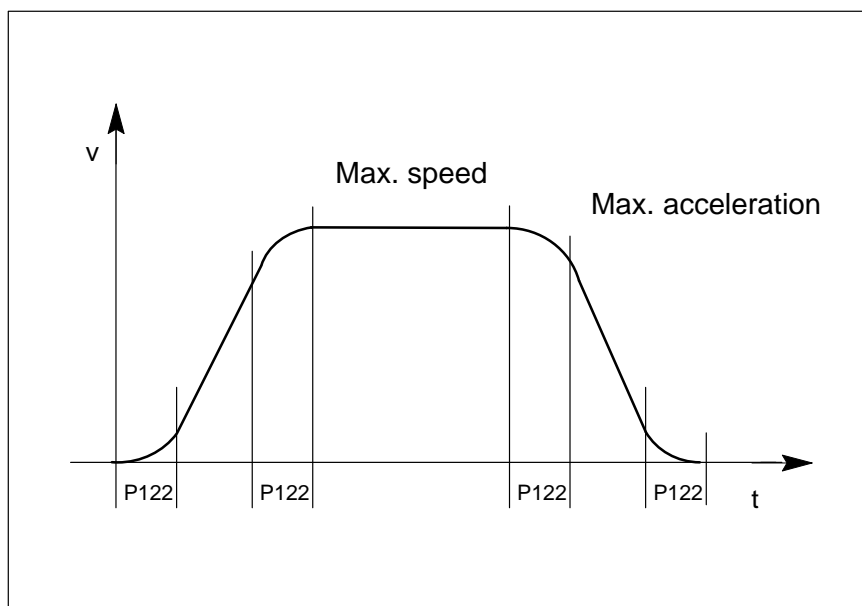

In the parameters 122 (123, 124, 130), the time is defined for the respective kind of movement for reaching the maximum acceleration resp. the time of deceleration to constant speed.

Positions

6 Positions

Group 200	Positions
P201	In-position range
P202	Positive software limit switches WC
P203	Negative software limit switches WC
P204	Positive software limit switches JC
P205	Negative software limit switches JC
P206	Software limit switches tolerance
P207	Reference point actual value
P208	Reference point offset
P209	Reserved
P210	Reserved
P211	Reserved
P212	Presetting of passing distances and factors
P213	Passing distances in JC
P214	Passing criterion

 **These machine parameters must be entered for each kinematic**

Positions

P201 Inpos range

With P201 the range is defined in which the axes must be located before the signal 'In-position all axes' is set to High. This also applies to the In-Pos signal of an individual axis. These criteria must be fulfilled before the next block will be executed. The input is made in mm resp. degrees.

 **This parameter considerably influences the positioning accuracy**

Display on the PHG

```
ROBI_1      MP SET
P201 <IN POS> -RANGE
A01        4.000
#
```

Entry in converter file

P201.InPosRange.Kin1.Axis1=4.000

P202 Positive software limit switches WC

With P202 the values of the positive software limit switches in world coordinates are defined. The input is made in mm resp. degrees.

Acts only in Jog mode.

Display on the PHG

```
ROBI_1      MP SET
P202 SW-LIM. POS WC
K01        9999.99
#
```

Entry in converter file

P202.SwLimPosWC.Kin1.Coord1=9999.99

P203 Negative software limit switches WC

With P203 the values of the negative software limit switches in world coordinates are defined. The input is made in mm resp. degrees.

Acts only in Jog mode.

Positions

Due to the kinematics involved, an internal travel range limit can be reached when moving in world coordinates in automatic or manual mode. The movement is immediately stopped and 'travel range limit reached' is displayed under operating mode diagnosis-error.

Display on the PHG

```

ROBI_1      MP SET
P203 SW LIM.S.NEG WC
K01        -9999.99
#

```

Entry in converter file

P203.SwLimNegWC.Kin1.Coord1= -9999.99

P204 Positive software limit switches JC

With P204 the maximum positive axis movements are defined. The input is made in mm resp. degrees.

If hardware limit switches are available, they must be taken into account for the entry. The software limit switches must always be located before the hardware limit switches.

If, for example, a software limit switch is approached in automatic mode, 'travel range limit xth axis' is displayed under mode Diagnosis-error.

In Jog mode JC, the axes are decelerated before reaching the software limit switch. The limit switch position is approached per ramp.

 **The values in P204 are only active if the reference points have been approached**

Display on the PHG

```

ROBI_1      MP SET
P204 SW LIM.S.POS JC
A01        360.000
#

```

Entry in converter file

P204.SwLimPosJc.Kin1.Axis1=360.000

Positions

Note concerning P204/P205

Servodyn-G coupling with transfer of the drive parameters. The values entered under P204 and P205 are transferred to the drive boosters for further monitoring.

For switching off the monitoring in the drives, e.g. with endless axes, the value 999990.0 must be entered in P204 and -999990.0 in P205.

P205 Negative software limit switches JC

With P205 the maximum negative axis movements are defined. The input is made in mm resp. degrees.

If hardware limit switches are available, they must be taken into account for the input.

If a software limit switch is approached in automatic mode, 'travel range limit xth axis' is displayed under mode Diagnosis-error.

 **The values in P205 are only active if the reference points have been approached**

Display on the PHG

```
ROBI_1      MP SET
P205 SW LIM.S.NEG JC
A01        -360.000
#
```

Entry in converter file

P205.SwLimNegJc.Kin1.Axis1=-360.000

P206 Software limit switch tolerance

With P206 the tolerance range of the software machine limit switches (JC) is defined. The input is made in mm resp. degrees.

If the entered tolerance is exceeded, the Ready contact is opened.

Under operating mode Diagnosis-error, e.g. the message 'Machine limit switch 1st axis' is displayed.

Positions

Display on the PHG

```

ROBI_1      MP SET
P206 SW LIM.S.TOLER
A01        1.500
#

```

Entry in converter file

```
P206.SwLimTol.Kin1.Axis1=1.500
```

P207 Actual value of reference point

With P207 the distance between axis zero point and reference point is entered. The input is made in mm resp. degrees.

With absolute encoders: distance between axis zero point and zero point of encoder.

To be able to use the full range of the encoder, the value should approach 0 as far as possible.

Display on the PHG

```

ROBI_1      MP SET
P207 REF.P. POSITION
A01        0.000
#

```

Entry in converter file

```
P207.RefPoiPos.Kin1.Axis1=0.000
```

Geometry between reference point and axis zero point

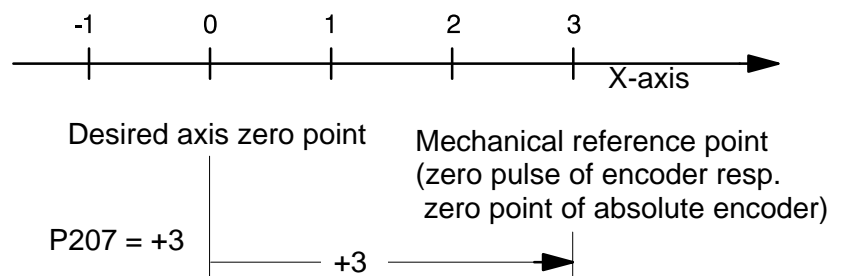

Example for P207 and P208:

- 1 The parameters P207 and P208 must contain the value 0.

Positions

- 2 Approach reference point.
- 3 Measure the axis zero point of the corresponding axis in manual mode – using a gauge.
- 4 Enter the position value read from point 3 into the reference point actual value P207.
- 5 The actual value displayed after reference point travel, is the actual reference point value (P207) minus reference point offset (P208).

☞ **At SERCOS and CanOpen, the actual reference point value is adjusted directly in the drive**

P208 Reference point offset

After the reference point recognition, the value set in P208 is approached as initial position. Axis zero point and reference point are not influenced by this. The input is made in mm resp. degrees.

The reference point offset is approached with the 1st reduced referencing speed.

Display on the PHG

```

ROBI_1      MP SET
P208 REF.P. OFFSET
A01         0.000
#

```

Entry in converter file

P208.RefPoiOff.Kin1.Axis1=0.000

P212 Presetting of passing distances and factors

P212 defines which passing distances and factors are effective at program start. With the BAPS command R the values predefined in P212 are overwritten. The input is made in mm resp. degrees.

By input of 0, passing can be disabled.

Display on the PHG

```

ROBI_1      MP SET
P212 PASS. DEFAULT
RAD         0.000
#

```

Positions

Entry in converter file

P212.PassDisWc.Kin1=0.000

Display on the PHG

ROBI_1	MP SET
P212 PASS. DEFAULT	
FAK	0.000
#	

Entry in converter file

P212.PassDisJc.Kin1=0.000

P213 Passing distances in JC

In P213 the axis-specific passing distances are defined onto which the factor R_PTP programmable in BAPS refers. The input is made in mm resp. degrees.

By input of 0, passing can be disabled.

Display on the PHG

ROBI_1	MP SET
P213 PASS.-DISTANCE	
A01	0.000
#	

Entry in converter file

P213.PassDist.Kin1.Axis1=0.000

P214 Passing type

P214 defines according to which passing criteria the values in parameter P213 are used.

Input possibilities:

- Axis criterion = 0
- Space criterion = 1

Positions

Display on the PHG

```
ROBI_1      MP SET  
P214 PASS.-CRIT. A/S  
(0/1)      0  
#
```

Entry in converter file

P214.PassCrit.Kin1=0

 **Acts only with PTP interpolation**

Kinematic parameters

7 Kinematic parameters

Group 300	Kinematic parameters
P301	Kinematic name
P302	Axis number of kinematic
P303	Axis type
P304	Axis name
P305	Coordinate name
P306	Selection of robot type and transformation
P307	Axis lengths
P308	Coupling factors
P309	Flange coordinate system
P310	World coordinate system offset
P311	Modulo value for endless axes
P312	Reserved
P313	Assignment of robot axis to world coordinates
P314	Serial number of electronic type plate

☞ **These machine parameters must be entered for each kinematic**

P301 Kinematic name

Kinematic names may consist of up to twelve ASCII characters.

☞ **Permitted characters are A to Z, 0 to 9 and the sign'_'.** The first character must be a capital letter

Display on the PHG

```

ROBI_1      MP SET
P301 NAME OF KINEM.
ROBI_1
#

```

Entry in converter file

```
P301.KinName.Kin1=ROBI_1
```

Kinematic parameters

P302 Axis number of kinematic

A kinematic may consist of up to 18 axes.

Display on the PHG

```
ROBI_1      MP SET
P302 NUMBER OF AXES
           2
#
```

Entry in converter file

P302.KinAxisNumb.Kin1=2

P303 Axis type

There are main, manual and endless axes.

The assignment is as follows:

- 0 = main axis
- 1 = manual axis
- 3 = endless axis as main axis
- 4 = endless axis as manual axis

 **For endless axes with Servodyn-G drives the software limit switch monitoring must be disabled with axis type 3 or 4 via P204/P205**

Display on the PHG

```
ROBI_1      MP SET
P303 TYPE OF AXES
A01  0
#
```

Entry in converter file

P303.AxisType.Kin1.Axis1=0

Kinematic parameters

P304 Axis names

An axis name may consist of up to three ASCII characters.

- ☞ **Permitted characters are A to Z, 0 to 9 and the sign'_'.** The first character must be a capital letter

Display on the PHG

```
ROBI_1      MP SET
P304 AX.NAMES ASCII
A1   A01
#
```

Entry in converter file

```
P304.AxisName.Kin1.Axis1=A01
```

P305 Coordinate names

A coordinate name may consist of up to three ASCII characters.

- ☞ **Permitted characters are A to Z, 0 to 9 and the sign'_'.** The first character must be a capital letter

Display on the PHG

```
ROBI_1      MP SET
P305 AX.COORD. ASCII
C1   K01
#
```

Entry in converter file

```
P305.AxisCoord.Kin1.Coord1=K01
```

Kinematic parameters

P306 Selection of robot type and transformation

For different robot types standard transformations are available which can be activated via the corresponding identification number.

 **This parameter is to be set at initial start-up according to the Bosch instructions**

Input possibilities:

- Robot type: the possible robot types depend on the current operating system version.
- Referencing of all axes (yes/no), yes = 1, no = 0. Normally = 0, must only be set to = 1 for specific transformations.
- Read POS with coordinate change (yes/no), yes = 1, no = 0. Normally = 0, must only be set to = 1 for specific transformations.
- Read POS of set position/actual position; (yes/no), yes = 1, no = 0. It is possible to select whether under the BAPS variable POS, the actual position (yes) or the set position (no) is to be stored.
- Endless axes in main range; (yes/no), yes = 1, no = 0.
 - Yes: the axis positions values can have the values between 0 and the value entered in P311.
 - No: the axis position values can have the values between -P311 to +P311.
- WC axis monitoring (monitoring of the axis speed)
 - 0 = No monitoring
 - 1 = Monitoring with movement abort.
 - 2 = Only in manual mode, monitoring with limitation of the axis speeds. No monitoring in automatic mode.
 - 3 = Do not use this setting. Activate monitoring with '4'.
 - 4 = In the manual and automatic operation, monitoring with limitation of the axis velocities. The limitation is effective for the whole movement.
 - 5 = Continuous monitoring of the axis velocity during linear movement

Please note:

- the monitoring occurs in manual operation on the high JC-Jog velocities adjusted in the machine parameter P114 and in automatic operation on the maximum axis velocities adjusted in P103.
- when the axis limitation takes place during the motion, the velocity at the TCP does not match the programmed velocity.
- when the axis limitation takes place, the path becomes inaccurate.

Kinematic parameters

Display on the PHG

```
ROBI_1      MP SET
P306 TYPE OF ROBOT
            10
#
```

Entry in converter file

P306.KinRobType.Kin1=10

Display on the PHG

```
ROBI_1      MP SET
P306 TYPE OF ROBOT
Reference all axis
#    0
```

Entry in converter file

P306.KinRefAllAx.Kin1=0

Display on the PHG

```
ROBI_1      MP SET
P306 TYPE OF ROBOT
Read POS on coord-ch
#    0
```

Entry in converter file

P306.KinIposCoord.Kin1=0

Display on the PHG

```
ROBI_1      MP SET
P306 TYPE OF ROBOT
Read POS: comm./act.
#    0
```

Entry in converter file

P306.KinIposComm.Kin1=0

Kinematic parameters

Display on the PHG

```

ROBI_1      MP SET
P306 TYPE OF ROBOT
Endl.ax.in main.Y/N
# 0

```

Entry in converter file

P306.KinEndless.Kin1=0

Display on the PHG

```

ROBI_1      MP SET
P306 TYPE OF ROBOT
Monitoring axis wc
# 0

```

Entry in converter file

P306.KinAxisConWc.Kin1=0

P307 Axis lengths

With parameter P307 the specific axis lengths for the robot-kinematics defined in P306 are entered. The input is made in mm.

Refer to the transformation documentation for the axis numbering.

Display on the PHG

```

ROBI_1      MP SET
P307 LENGTH OF AXIS
Ax.-Length1 445.000
#

```

Entry in converter file

P307.KinAxisLeng.Kin1.Arm1=445.000 (dependent on robot type, P306)

P308 Coupling factors

With P308 the coupling factors for the robot-kinematics defined in P306 are entered and with their help, mechanical couplings between individual axes are described.

Kinematic parameters

Display on the PHG

ROBI_1	MP SET
P308 AX.-COUPL.FACT	
C-Factor 1	0.000
#	

Entry in converter file

P308.KinCoupFact.Kin1.Factor1=0.000

P309 Flange coordinate system

With parameter P309 different gripper systems for the robot-kinematics defined in P306 can be applied (also off-center).

Refer to the transformation documentation for the definition of the flange coordinate system.

The flange coordinate system is defined by six parameters. These are composed of three positions and three orientations.

The input range is between -100000.0 and +100000.0

Display on the PHG

ROBI_1	MP SET
P309 FLANGE COORDIN.	
Flange_X	0.000
#	

ROBI_1	MP SET
P309 FLANGE COORDIN.	
Flange_O1	0.000
#	

Entry in converter file

P309.KinFlangeCooX.Kin1=0.000
P309.KinFlangeCooO1.Kin1=0.000

Display on the PHG

ROBI_1	MP SET
P309 FLANGE COORDIN.	
Flange_Y	0.000
#	

ROBI_1	MP SET
P309 FLANGE COORDIN.	
Flange_O2	0.000
#	

Entry in converter file

P309.KinFlangeCooY.Kin1=0.000
P309.KinFlangeCooO2.Kin1=0.000

Kinematic parameters

Display on the PHG

ROBI_1	MP SET
P309 FLANGE COORDIN.	
Flange_Z	0.000
#	

ROBI_1	MP SET
P309 FLANGE COORDIN.	
Flange_O3	0.000
#	

Entry in converter file

P309.KinFlangeCooZ.Kin1=0.000
 P309.KinFlangeCooO3.Kin1=0.000

P310 Offset of the world coordinate system

With P310 the user is able to shift the zero point of the world coordinates. This facilitates the exchange of the robot mechanics. The input is made in mm.

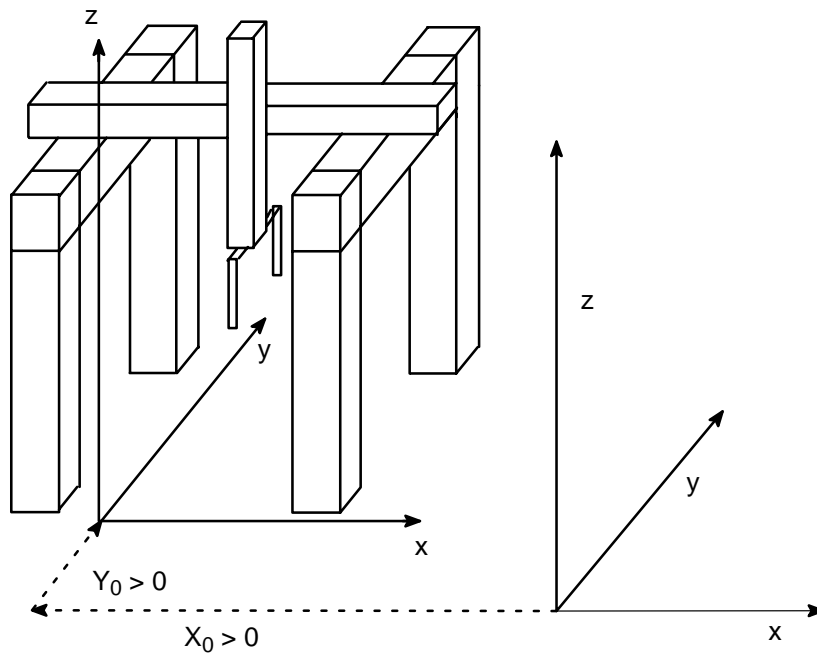

Display on the PHG

ROBI_1	MP SET
P310 OFFSET WC-SYST.	
X_0	0.000
#	

Kinematic parameters

Entry in converter file

P310.KinWcCoorOffX.Kin1=0.000

Display on the PHG

ROBI_1	MP SET
P310 OFFSET WC-SYST.	
Y_0	0.000
#	

Entry in converter file

P310.KinWcCoorOffY.Kin1=0.000

Display on the PHG

ROBI_1	MP SET
P310 OFFSET WC-SYST.	
Z_0	0.000
#	

Entry in converter file

P310.KinWcCoorOffZ.Kin1=0.000

P311 Modulo value for endless axes

P311 defined the value for the modulo computation of the control internal positions. The input is made in mm resp. degrees.

Example

With the help of the modulo value it is possible to detect when an endless axis has reached the position value for a complete rotation. Corresponding to the modulo computation, the rotation value is subtracted and the remaining value is set as actual value.

The value of P311 becomes only effective if in parameter P303 the corresponding axis has been declared as endless axis.

The modulo computation is not active in manual mode.

Kinematic parameters

Display on the PHG

```

ROBI_1      MP SET
P311 MOD-VAL ENDL.AX
A01        1.000
#
    
```

Entry in converter file

P311.ModValue.Kin1.Axis1=1.000

P313 Assignment of robot axes to world coordinates

P313 defines the assignment of the robot axes to the world coordinates in the function workpiece coordinates. Not defined coordinates resp. orientations are not taken into account when switching over to the workpiece coordinate system.

The function workpiece coordinates is only active in world coordinates (WC). In the function workpiece coordinates, a standard processing program is adapted to different workpiece carriers.

The orientations are located clock-wise-rotating round the respective axis of the world coordinates, seen from the coordinate origin.

 **This parameter is only relevant with kinematics with missing degrees of freedom (i.e. < 6 axis)**

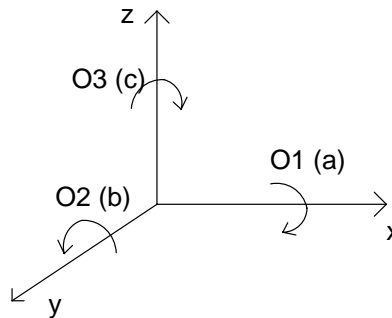

Display on the PHG

```

ROBI_1      MP SET
P313 WCSYS-ROB-ASSIG
WCSYS-x      0
#
    
```

```

ROBI_1      MP SET
P313 WCSYS-ROB-ASSIG
WCSYS-a      0
#
    
```

Entry in converter file

P313.KinWcSysAssgx.Kin1=0
P313.KinWcSysAssga.Kin1=0

Kinematic parameters

Display on the PHG

ROBI_1	MP SET
P313 WCSYS-ROB-ASSIG	
WCSYS-y	0
#	

ROBI_1	MP SET
P313 WCSYS-ROB-ASSIG	
WCSYS-b	0
#	

Entry in converter file

P313.KinWcSysAssgy.Kin1=0
P313.KinWcSysAssgb.Kin1=0

Display on the PHG

ROBI_1	MP SET
P313 WCSYS-ROB-ASSIG	
WCSYS-z	0
#	

ROBI_1	MP SET
P313 WCSYS-ROB-ASSIG	
WCSYS-c	0
#	

Entry in converter file

P313.KinWcSysAssgz.Kin1=0
P313.KinWcSysAssgc.Kin1=0

P314 Serial number of electronic type plate

The parameter P314 contains the serial number of the robot (SR6/SR8).
The serial number consists of 64 characters.

★ For moving the cursor within the input line, actuate



Display on the PHG

ROBI_1	MP SET
P314 SERIAL NUMBER	
#Grundinitialisierung	

Entry in converter file

P314.Seriesnumber.Kin1=Basic initialization of the electro. type plates

Kinematic parameters

Notes:

Measuring system parameters

8 Measuring system parameters

Group 400	Measuring system parameters
P401	Equipment of the measuring system boards
P402	Referencing direction
P403	Activity of reference point switch
P404	Analog outputs
P405	Assignment of analog outputs
P406	Analog inputs
P407	Assignment of analog inputs

8.1 P401 Equipment of the measuring system boards

Each axis and each belt requires a measuring system assigned to it. At each run-up of the control the layout of the measuring systems is checked.

For belts, it may be useful to assign different belts to one measuring system only.

A module number must be allocated to each input of a servo board.

Each measuring system has a measuring system number or a slot number XYZ, e.g. X51

Equal measuring systems are numbered consecutively. With different measuring systems, the numbering starts again with XYZ.

- X: slot designation
- Y: 1, 4 and 5 depends on measuring system
- Z: consecutive number

Key combination for scrolling in the parameter menu



 **Parameter 401 must be terminated with <Enter> to ensure that changed parameters are taken over**

Measuring system parameters

1. Subquery: Servo board

Indication of the number of the occupied servo board (always 1 at the moment).

Display on the PHG

```

ROBI_1      MP SET
P401 CONST.M.S.BOARD
A01      Servo-B.: 1
#
    
```

Entry in converter file for axes

P401.SbNum.Kin1.Axis1=1

Entry in converter file for belts

P401.SbNum.Kin1.Belt1=1

2. Subquery: Slot number

The slot number consists of three characters, e.g. X51.

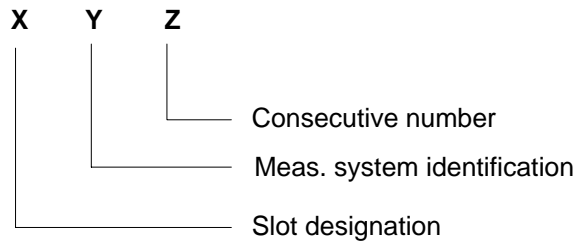

The following measuring system identifications are possible:

- 4 Incremental measuring system – module board –
Input: X41
- 5 CAN measuring system
Input: X51, X52
- 7 SERCOS measuring system
Input: X71

Display on the PHG

```

ROBI_1      MP SET
P401 CONST.M.S.BOARD
A01      CAN Plug: X51
#
    
```

Measuring system parameters

Entry in converter file for axes

P401.SlotNum.Kin1.Axis1=X51

Entry in converter file for belts

P401.SlotNum.Kin1.Belt1=X51

3. Subquery: Module number (depending on measuring system)

a) CAN- and incremental encoder:

For CAN applies:

- CAN bus 1 = module No. 1
- CAN bus 2 = module No. 2

3 must always be entered as module No. for an incremental encoder.

Display on the PHG

```
ROBI_1      MP SET
P401 CONST.M.S.BOARD
A01  --- Module No: 3
#
```

Entry in converter file for axes

P401ModulNum.Kin1.Axis1=3

Entry in converter file for belts

P401ModulNum.Kin1.Belt1=3

b) Sercos ring

Indication of the Sercos ring for the corresponding axis. At the present time, there is only one ring, i.e. a "1" must be entered.

Display on the PHG

```
ROBI_1      MP SET
P401 CONST.M.S.BOARD
A01  SCS Ring No.: 1
#
```

Entry in converter file for axes

P401SERCOSRing.Kin1.Axis1=1

Measuring system parameters

4. Subquery (dependent on measuring system)

a) Incremental measuring system:

Marker distance

The measuring system marker distance is the number of pulses between two marker signals (zero pulses).

Example: ROD 420 = 2500 pulses/rotation

For glass scales, the marker monitoring can be switched off by input of -1.

Display on the PHG

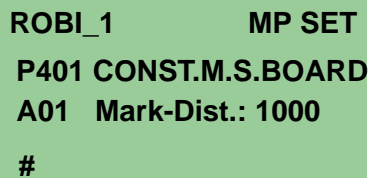

```
ROBI_1      MP SET
P401 CONST.M.S.BOARD
A01 Mark-Dist.: 1000
#
```

Entry in converter file

P401.IncMarkDis.Kin1.Axis1=1000

b) CAN interface:

Axis number

Definition of the axis address on the respective bus.

For Servodyn-G applies:

Axis address consecutive and slot-coded, see illustration.

The booster racks need not be fully equipped. Gaps between the boosters are also permitted. It only has to be ensured that the axis numbers are entered according to the actual equipment.

If a drive booster occupies two slots, the right-hand slot of the two must be entered as axis number for the CAN module input.

Measuring system parameters

CAN booster assignment - input number (Servodyn-G)

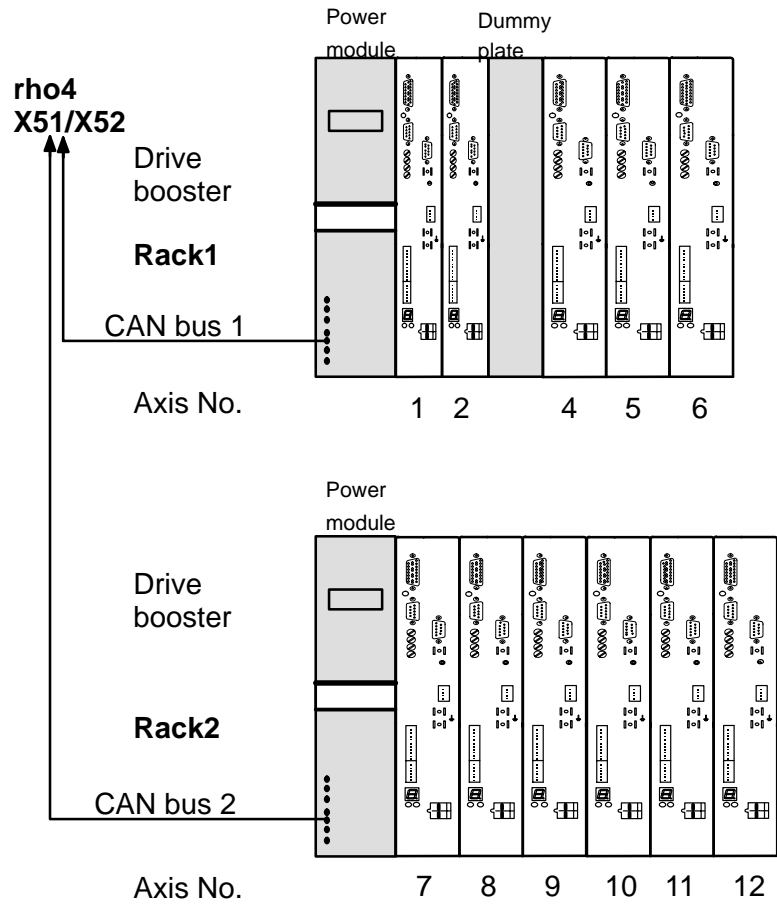

Measuring system parameters

For Servodyn-D applies:

The axis address can be set at the booster via rotary switch at the front panel, see Servodyn-D description. At the rho4, the set axis address must be entered as axis number.

It must be ensured that no axis address is used several times on a bus and also that there are no crossovers with identifiers of CAN I/O modules, see P31 / P32.

The identifier for drives are as follows:

Identifier for setpoint values (outputs) = axis address * 10 + 200

Identifier for actual values (inputs) = axis address * 10 + 600

Display on the PHG

```

ROBI_1      MP SET
P401 CONST.M.S.BOARD
A01  CAN Axis No.: 1
#

```

Entry in converter file for CANrho axis

P401.CANModAxNum.Kin1.Axis1=1

Entry in converter file for CANopen axis

P401.CANNodeID.Kin1.Axis1=1

c) SERCOS axis number

Indication of the SERCOS-Address of the corresponding drive amplifier (corresponds to the personality-module setting in the drive amplifier).

Allowed values: -127 to +127.

Display on the PHG

```

ROBI_1      MP SET
P401 CONST.M.S.BOARD
A01  SCS Axis No: 1
#

```

Entry in converter file for axes

P401.SERCOSModAxNum.Kin1.Axis1=1

Measuring system parameters

Drive type

Determination which axis is used.

Number of parameters	1	
Permitted values	0/1/2/5/10/11	
Input	0	Servodyn-G axis (CANrho protocol)
	1	Servodyn-D axis (CANrho protocol)
	2	CANopen axis
	5	CANopen encoder (belt)
	10	SERCOS Bosch
	11	SERCOS, reserved for sub-supplied products

Display on the PHG

```

ROBI_1      MP SET
P401 CONST.M.S.BOARD
A01      Drive 0
G=0, D=1, Co=2, Be=5 #

```

Entry in converter file for CAN axis

P401.CANDriveMode.Kin1.Axis1=0

Entry in converter file for SERCOS axis

P401.SERCOSDriveMode.Kin1.Axis1=10

Measuring system parameters

Transmitter path /Rotation

Inquiry occurs only when drive type = 2, 10 or 11.

Path of the axis per encoder rotation (in mm).

This parameter is required for the RC-lead referencing at SERCOS and CANopen (in preparation).

Display on the PHG

```
ROBI_1      MP SET
P401 CONST.M.S.BOARD
A01 dist/rot: 100.00
#
```

Entry in converter file for CAN axis

P401.CANDistancePerRevolution=100.00

Entry in converter file for SERCOS axis

P401.SERCOSDistancePerRevolution=100.00

Number of rotations

- For a Servodyn-D drive with absolute encoder, the number of rotations of the absolute encoder must be entered.
- For a resolver measuring system enter the value 1.

Number of parameters 1

Permitted values 1 to 4096

Display on the PHG

```
ROBI_1      MP SET
P401 CONST.M.S.BOARD
A01 rotations: 512
#
```

Entry in converter file

P401.CANPulseRate.Kin1.Axis1=512

Measuring system parameters

Zero point offset

- With a Servodyn-D drive with resolver measuring system, the zero point offset of the encoder must be indicated.

Number of parameters 1

Permitted values Dependent on measuring system converter

Display on the PHG

```

ROBI_1          MP SET
P401 CONST.M.S.BOARD
A01 Pos-Offs: 0
#
  
```

Entry in converter file

P401.CANOffset.Kin1.Belt1=0

Referencing mode

Mode = 0: reference point travel normal

The axis travels to the next zero crossing of the measuring system after having recognized the reference point switch.

Mode = 1: reference point travel with correct orientation

With specific Scara kinematics it can happen that the gripper rotational axis executes more than one rotation because of missing mechanical stops. The control must make sure that the gripper axis is first rotated back if referencing is started when the gripper is not in correct position.

The position of the gripper quill is measured by a resolver measuring system on the motor shaft which measures absolutely over 360° when the reference point is reached.

The motor axis rotates in contrast to the quill axis via a gear with a non-integral transfer ratio. From the quill position it is possible to calculate for how many rotations it has moved away from the reference point.

MODE = 2: reference point travel resolver-suitable

The axis does not travel to the next zero point after the reference point switch has been recognized. When the reference point switch is reached, the resolver position is read in and the axis stops immediately.

MODE = 3

Combination of MODE 1 and MODE 2

Measuring system parameters

Display on the PHG

```
ROBI_1      MP SET
P401 CONST.M.S.BOARD
A01 Ref.-Mode: 0
#
```

Entry in converter file for CAN axis

```
P401.CANRefMode.Kin1.Axis1=0
```

Entry in converter file for SERCOS axis

```
P401.SERCOSRefMode.Kin1.Axis1=0
```

Gear factor

Inquiry only if ref. mode = 1 or ref. mode = 3.

Input must contain decimal place.

Display on the PHG

```
ROBI_1      MP SET
P401 CONST.M.S.BOARD
A01 GearFact: 0.500
#
```

Entry in converter file for CAN axis

```
P401.CANGearFac.Kin1.Axis1=0.500
```

Entry in converter file for SERCOS axis

```
P401.SERCOSGearFac.Kin1.Axis1=0.500
```

Modulo value

Inquiry occurs only when drive type = 2, 10 or 11.

The modulo value is to be set for RC-lead referencing and endless axes. The module interface must be also adjusted suitably at the drive booster. The modulo value at the drive booster (C-2067) must match the rho4-modulo value described here by taking into account the weighting (C-6089). The modulo value must be at least so high that the half modulo value per scanning time (P5) is reached when the axis velocity is maximum.

Measuring system parameters

Display on the PHG

```

ROBI_1      MP SET
P401 CONST.M.S.BOARD
A01  Mod-value 360
#

```

Entry in converter file for CAN axis

```
P401.CANModuloValue.Kin1.Axis1=360
```

Entry in converter file for SERCOS axis

```
P401.SERCOSModuloValue.Kin1.Axis1=360
```

Pulses per rotation

See instructions of manufacturer for drive booster

Display on the PHG

```

ROBI_1      MP SET
P401 CONST.M.S.BOARD
A01  puls/rot. 16384
#

```

Entry in converter file

```
P401.CANResPCount.Kin1.Axis1=16384
```

5. Subquery: Measuring system factor

Under measuring system factor, the number of the encoder increments per degree resp. per mm axis movement must be entered. This is dependent on the mechanics just as gear or ball roller spindle etc.

A negatives sign for the measuring system factor (MSfact) means reversal of direction. Rewiring of the encoder is not necessary. With a reversal of direction the assignment of the command output must equally be negated in subquery 6. This only applies to incremental encoders and CAN, not for absolute measuring systems.

- Computation of increments per degree resp. per mm:

MSF = measuring system factor

$$\text{MSF} = \frac{\text{Incr}}{\text{distance}}$$

Measuring system parameters

Incr corresponds to increments per encoder rotation

Distance distance covered per encoder rotation (with gear)

- Pulse quadruplication:

The number of encoder pulses (incr) must be multiplied by 4 for incremental measuring systems.

Example:

Incremental encoder 2000 pulses/rotation

Covered distance for 1 incremental encoder rotation = 12.18 mm

$$\text{MSF} = \frac{2000 * 4}{12.18} = 656.8144$$

- For Servodyn-GC applies:

$$\text{MSF} = \frac{\text{pulses/rotation}}{\text{distance}}$$

- For Servodyn-D applies:

$$\text{MSF} = \frac{8192}{\text{distance}}$$

The encoder accuracy should be 10 times better than demanded at the machine and at least 500 pulses/rotation for motor-flanged encoders.

- For Bosch Rexroth SERCOS drives applies:

$$\text{MSF} = 1000.00$$

- For external encoders at the ECODRIVE, resp. IndraDrive applies:

$$\text{MB} = \frac{360}{\text{feed rate constant}} * 1000$$

For an external encoder, there is no possibility in the drive to enter a gear factor resp. a feed rate constant. Therefore the actual measuring system factor must be adjusted in the rho4.

Entering 1000, the position value of the drive is assumed 1:1 accordingly the settings in the drive; i.e. the calculated measuring system factor must be multiplied by 1000 for the input.

Measuring system parameters

Display on the PHG

```

ROBI_1      MP SET
P401 CONST.M.S.BOARD
A01  ms.fact: 1000.00
#

```

Entry in converter file for axes

```
P401.MeaSysFactor.Kin1.Axis1=1000.00
```

Entry in converter file for belts

```
P401.MeaSysFactor.Kin1.Belt1=1000.00
```

6. Subquery: Assignment of the command outputs

A command output must be assigned to each servo loop. Numbering is consecutive starting from 1.

For CAN coupling, numbering has only internal significance. Numbering is consecutive and in ascending order. The actual assignment of the axes is only carried out via the axis number.

 **By input of a negative command output the setpoint is turned. With direction reversal, the assignment of the measuring system factor must equally be negated in the 5th subquery.**

Display on the PHG

```

ROBI_1      MP SET
P401.CONST.M.S.BOARD
A01  Com.output: 1
#

```

Entry in converter file

```
P401.ComOutput.Kin1.Axis1=1
```

7. Subquery: Dss reference

Inquiry occurs only with CANopen axis and CANopen encoder (drive type = 2 or 5).

Measuring system parameters

The DssRef is used as reference between identifier and axis number in the Dss. For each applicated axis, the corresponding axis number must be given in the Dss. For each peripheral unit (axis, encoder, I/O module), an ASCII file must be created, in which the CANopen specific parameters are set. The number contained in the name of the ASCII file must be given in the parameter Dss-Ref to create the relation between the rho4 and the ASCII file (see also chapter 3, section 3.3.4 XMP converter).

Possible entries:

- **CANopen encoder**
 - 0 Use Default parameter
 - 1 to 24 Use parameter from ASCII file for corresponding axis
 - 1 Switch off parameter download for corresponding axis

- **CANopen axis**
 - 0 Switch off parameter download for corresponding axis
 - 1 to 24 Use default settings + parameter from ASCII file for corresponding axis
 - 1 to -24 Use only parameters from ASCII file for corresponding axis

Display on the PHG

```
ROBI_1      MP SET
P401.CONST.M.S.BOARD
A01 DSS-Ref: 1
#
```

Entry in converter file

P401.CANDSSRef.Kin1.Axis1=1

Measuring system parameters

8.2 P402 Direction of reference point travel

With P402 the direction of the reference point travel is defined.

Input:

-1 = negative referencing direction

+1 = positive referencing direction

0 = no referencing

Display on the PHG

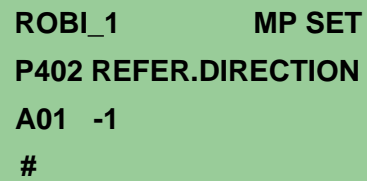

```
ROBI_1      MP SET
P402 REFER.DIRECTION
A01 -1
#
```

Entry in converter file

P402.RefDir.Kin1.Axis1=-1

Measuring system parameters

8.3 P403 Effectiveness of reference point switch

With P403 the evaluation of the reference point switch is entered.

Input:

-1 = falling edge of switch

+1 = rising edge of switch

0 = no switch (only permitted if P402 = 0)

Display on the PHG

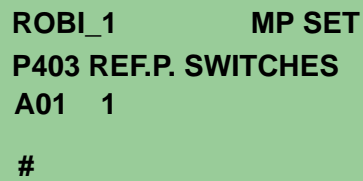

```
ROBI_1      MP SET
P403 REF.P. SWITCHES
A01  1
#
```

Entry in converter file

P403.RefPoiSwt.Kin1.Axis1=1

Measuring system parameters

8.4 P404 Number of analog outputs

This parameter gives the number of the analog output channels. Four analog output channels are to be adjusted per output block.

Display on the PHG

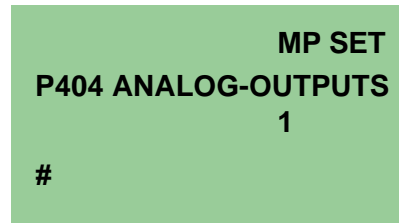

Entry in the converter file

P404.NumberAnalogOutputs=1

8.5 P405 Assignment of analog outputs

In this parameter, the assignment, RAM address of the analog channel, data format, nominal value and voltage offset are to be entered.

a) Assignment

The first digit of the 3-digit assignment number subdivides the output assignment into different classes. Following output signals can be output on analog output channels:

- 1XX Output of actual position of axis XX or belt XX
(XX = 1 .. axis number + belt number)
- 2XX Decimal output in a BAPS program
The adjusted channel number must be used in the BAPS program for declaration of the analog output
- 3XX Output set-position of axis XX
- 400+Kin-No Output set-path velocity of kinematic X
- 450+Kin-No Output of actual path velocity of kinematic X
(only for robot type = 0, machine parameter P306)
- 5XX Output after-running of axis XX
- 6XX Output set-velocity of axis XX
- 7XX Output actual velocity of axis XX or belt XX
(XX = 1 .. axis number + belt number)

Measuring system parameters

Display on the PHG

```
ANA-Out. 1      MP SET
P405 MEAN. OF A.-OUT
Meaning: ACT-POS A-1
#
```

Entry in the converter file

```
P405.AnalogOutAlloc.Output1=101
```

b) RAM initial address

This relative address gives the situation of the 2-byte-data word for the analog channel within the rho4 internal RAM area. For inputs and outputs, there are 2 RAM areas that are physically separated. The setting is to be performed as follows:

```
0 RAM-BegAdr ANA-Out. 1
2 RAM-BegAdr ANA-Out. 2
4 RAM-BegAdr ANA-Out. 3
6 RAM-BegAdr ANA-Out. 4
(n-1)*2 RAM-BegAdr ANA-Out. n
```

 **The adjusted RAM addresses must match the initial addresses adjusted in P32**

Display on the PHG

```
ANA-Out. 1      MP SET
P405 MEAN. OF A.-OUT
RAM-BegAdr: 0
#
```

Entry in the converter file

```
P405.AnalogOutStartAddr.Output1=0
```

Measuring system parameters

c) Format

For the output assignment 2XX (BAPS output), it is possible to choose in the data format between a numeral representation in the pair complement (positive and negative decimal numbers : format =0) and a representation in Straight Binary (only positive decimal numbers : format=1).

For all other assignments (1XX, 3XX, 4XX, 5XX, 6XX, 7XX), the data format pair complement (positive and negative decimal numbers : format =0) is obligatory. The path velocity output (4XX) supplies in the data format pair complement only positive values.

Display on the PHG

```
ANA-Out. 1      MP SET
P405 MEAN. OF A.-OUT
Format:  0
#
```

Entry in the converter file

P405.AnalogOutFormat.Output1=0

d) Nominal value

The nominal value is the number corresponding with an offset of 0 to the greatest output value that can be represented with 2 bytes. If one outputs in the BAPS program the nominal value on an analog output, the maximum value of the adjusted voltage range (or current output range) is obtained on condition that a left justified representation has been selected.

In the case of a right justified representation and a resolution of 12 bits (example: 4AO_U-module) the maximum value is output at 1/16 of the nominal value.

Display on the PHG

```
ANA-Out. 1      MP SET
P405 MEAN. OF A.-OUT
Nom.val.:  1000.00
#
```

Entry in the converter file

P405.AnalogOutNominalValue.Output1=1000.00

Measuring system parameters

e) Offset

In analog outputs, a voltage offset can be adjusted, which is added to the output value. The offset is given as %-value of the maximum voltage (current).

Display on the PHG

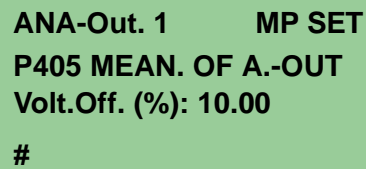

ANA-Out. 1 MP SET
P405 MEAN. OF A.-OUT
Volt.Off. (%): 10.00
#

Entry in the converter file

P405.AnalogOutVoltageOffset.Output1=10.00

Measuring system parameters

8.6 P406 Number of analog inputs

This parameter gives the number of the analog input channels. Four analog input channels are to be adjusted per input block.

Display on the PHG

```

MP SET
P406 ANALOG-INPUTS
1
#

```

Entry in the converter file

P406.NumberAnalogInput=1

8.7 P407 Assignment of the analog input channels

In this parameter, the BAPS channel numbers (assignment), RAM initial address of the analog channel, data format and nominal value are to be entered.

a) Assignment

BAPS channel numbers from 210 to 299 are allowed. The adjusted channel number must be used in the BAPS program for declaration of the analog input of type REAL.

Example: OUTPUT REAL: 201=ANA_IN_1

Display on the PHG

```

ANA-Inp. 1      MP SET
P407 MEAN. OF A.-IN
Meaning: REAL: 201
#

```

Entry in the converter file

P407.AnalogInAlloc=201

Measuring system parameters

b) RAM initial address

This relative address gives the situation of the 2-byte-data word for the analog channel within the rho4 internal RAM area. For inputs and outputs, there are 2 RAM areas that are physically separated. The setting is to be performed as follows:

0 RAM-BegAddr ANA-Inp 1
 2 RAM-BegAddr ANA-Inp 2
 4 RAM-BegAddr ANA-Inp 3
 6 RAM-BegAddr ANA-Inp 4
 (n-1)*2 RAM-BegAddr ANA-Inp n

 **The adjusted RAM addresses must match the initial addresses adjusted in P32**

Display on the PHG

```
ANA-Inp. 1      MP SET
P407 MEAN. OF A.-IN
RAM-BegAdr: 0
#
```

Entry in the converter file

P407.AnalogInStartAddr.Input1=0

c) Format

It is possible to choose in the data format between a numeral representation in the pair complement (positive and negative decimal numbers : format =0) and a representation in Straight Binary (only positive decimal numbers : Format=1).

Display on the PHG

```
ANA-Inp. 1      MP SET
P407 MEAN. OF A.-IN
Format: 0
#
```

Entry in the converter file

P407.AnalogInFormat.Input1=0

Measuring system parameters

d) Nominal value

The nominal value is the number corresponding with an offset of 0 to the greatest output value that can be represented with 2 bytes. This means that in the BAPS program the entered nominal value is obtained by reading an analog input supplying the maximum possible analog input.

For a nominal value of 1000 and a measuring range of ± 10 V, an input value of 1000 is obtained in the BAPS program for an applied voltage of +10 V on condition that a left justified representation and Format=0 has been selected.

In the case of a right justified representation and a resolution of 12 bits (example: 4AI_UI-module), only 1/16 of the nominal value is reached as maximum value. For an applied voltage of 10V, an input value of 62.5 is therefore read in the BAPS program.

Display on the PHG

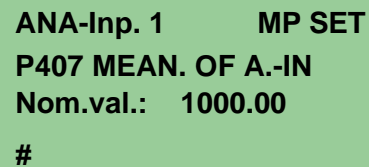

ANA-Inp. 1 MP SET
P407 MEAN. OF A.-IN
Nom.val.: 1000.00
#

Entry in the converter file

P407.AnalogInNominalValue.Input1=1000.00

Measuring system parameters

Notes:

Belt parameters

9 Belt parameters

Group 500	Belt parameters
P501	Number of belts
P502	Reserved
P503	Belt coupling factor
P504	Reserved
P505	Limit values for belt counter
P506	Belt name
P507	Belt time offset
P508	Belt simulation velocity
P509	Belt actual value/set value

Belt inputs (measuring systems) can be freely selected. The setting is performed via parameter P401 analogous to the controlled axes. Measuring systems can be assigned several times with belts.

Measuring system inputs of controlled axes can also be additionally used as belt inputs. This makes it possible to couple several axes via belt synchronization. The coupling factor which is to be applied between the axes can be freely selected via parameter P503.

Starting of belt synchronous procedures is carried out via a corresponding programming in the BAPS program. The proceeding is described in the BAPS3 programming instructions.

 **The following parameters can be set for each kinematic**

Belt parameters

P501 Number of belts

The maximum number of belts is 16. This total number can be distributed to the kinematics available.

Display on the PHG

ROBI_1	MP SET
P501 NUMBER OF BELTS	
	1
#	

Entry in converter file

P501.KinBeltNumb.Kin1=1

P503 Belt coupling factor

- One value per coordinate, X, Y, Z.
- Specification of the cosine value ($\cos \alpha$) of the angle enclosed between the belt and the corresponding coordinates.
- Coupling factor between belt axis and axis to be coupled of a subsequent drive.

Example

If the belt is parallel to the Y-axis, then the Y-value = 1. The X and Z-values are 0.

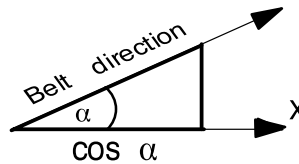

Display on the PHG

ROBI_1	MP SET
P503 COUPLING-FACTOR	
BN1 A_X	0.000
#	

Entry in converter file

P503.BeltDirCos.Kin1.Belt1.Coord1=0.000

Belt parameters

P505 Limit values for belt counter

Display on the PHG

```

ROBI_1      MP SET
P505 LIM. BELTCOUNT.
BN1 MIN.    -5000
#
  
```

Minimum and maximum value:

Entry in converter file

P505.BeltCoLimMin.Kin1.Belt1=-5000

P505.BeltCoLimMax.Kin1.Belt1=5000

 **Input of 0 switches off the limit value monitoring!**

P506 Belt name

For the belt name a length of three ASCII characters is permitted.

Display on the PHG

```

ROBI_1      MP SET
P506 BELT-NAMES
NAME BELT 1: BN1
#
  
```

Entry in converter file

P506.BeltName.Kin1.Belt1=BN1

P507 Belt time offset

Positioning errors on the running belt caused by the lags of the affected axes, can be compensated via the belt time offset.

Setting of the time offset

- If a belt-parallel axis is available

$$\text{Time offset [ms]} = \frac{\text{Nominal lag [mm]} * 1000}{V_{\text{max}} [\text{mm/s}]}$$

Belt parameters

Nominal lag Nominal lag of the belt-parallel axis (P101)

V_{max} Maximum axis speed of the belt-parallel axis (P103)

- ★ Empiric determination if several axes are included in the belt-parallel movement

- 1 Set time offset to = 0
- 2 Position the roboter on the belt above the position to be synchronized (workpiece)
- 3 Start belt while belt synchronization is switched on
- 4 Measure lag (distance) during movement between the robot position (gripper) and the belt position (workpiece)
- 5 Determine time offset by the following formula

$$\text{Time offset [ms]} = \frac{\text{measured lag [mm]} * 1000}{\text{Act. } V_{\text{belt}} [\text{mm/s}]}$$

- 6 Check lag and determined time offset once more, add new lag to preceding lag, calculate new time offset and enter it.

Display on the PHG

```

ROBI_1      MP SET
P507 BELT TIME OFFS.
BN1        0.0000
#
    
```

Entry in converter file

P507.BeltTimeOff.Kin1.Belt1=0.0000

P508 Belt simulation velocity

For testing belt-synchronous movements without an active belt, a belt velocity can be preset via machine parameter P508. This velocity is taken for simulation operation instead of the actual belt velocity in the movement procedure. Input is made in mm/sec.

Display on the PHG

```

ROBI_1      MP SET
P508 BELT SIM-VELOC.
BN1        0.000
#
    
```

Entry in converter file

P508.BeltSimVel.Kin1.Belt1= 0.000

Belt parameters

P509 Belt actual value/set value

For cam disk applications (Belt type 3), it may be useful that all concerned axes – including the master axis – keep their set value as instantaneous as possible. If the actual value of the master axis for the belt synchronization is used, it results a time shift between master axis and the slave axes of about 5–6 clock times.

If the master axis and the slave axes of the cam disk application are operated by the same rho4, it is possible to adjust per machine parameter (P509) alternatively actual value or set value coupling. For the set value coupling, the time difference between master and slave axis is canceled. The phase shift of the concerned axes then depends mainly on the lags of the different axes and can be optimized via axis parameter (e.g. pilot control).

Master and slave axes on the same rho4 are prerequisite for a set value coupling. For each belt, the machine parameter P509 Actual/Set value can be set.

P509 = 0 (default) The source is the encoder or the axis actual value

P509 = 1 The source is the axis set value

The belt buffers are filled for P509 = 0 depending on the axis actual values or encoders, As for all other belt logics, the same axis set value can be taken as source for several belts.

All controlled axes supported on the rho4 can be used as source:

- Servodyn-G drives
- Servodyn-D drives with CAN-rho protocol
- Drives with CANopen protocol
- Drives with SERCOS protocol

Display on the PHG

```

ROBI_1      MP SET
P509 BELTACTV/SETV
BN1      0
#

```

Entry in converter file

P509.BeltActValSetVal.Kin1.Belt1=0

Belt parameters

Notes:

Drive parameters Servodyn-GC

10 Drive parameters Servodyn-GC

Group 600	Drive parameters Servodyn-GC
P601	Perform parameter transfer
P602	Drive booster type
P603	Motor type
P604	Proportional value of the velocity controller
P605	Integral value of the velocity controller
P606	Proportional gain of the position controller
P607	Torque limit values
P608	Emergency stop deceleration ramp
P609	Velocity limit value of braking
P610	Maximum static positioning error
P611	Maximum lag error
P612	Filter band width, torque signal
P613	Damping factor, Zeta
P614	Home position offset, position return back signal
P615	Overtemperature protection

 **The defined limit values of the drive parameters are partly higher than the maximum permitted values of the drive boosters. This makes it possible to enter, via the rho4-machine parameter program, values for amplifier types not existing at the moment. If in the machine parameter program values have been entered which are not accepted by the respective amplifier, the parameter transfer is stopped with the corresponding error message.**

Transfer of the drive parameters

The drive parameters stored in the rho4.1 are transferred to the drive boosters in the run-up phase. It is, however, still possible to enter the parameters directly at the drive booster.

Parameters with a dependency between control and drive, as e.g. scanning cycles, are defined directly from the available control parameter. Parameters already defined in the control as e.g. software limit switches are handled analogously.

This refers to the following:

Communication_Cycle_Period (CLOCK start time)

The value for the rho4 Clock start time P5 is transferred as Communication_Cycle_Period to the drive booster.

Drive parameters Servodyn-GC

Software_Limit_Positions (software limit switches)

The software limit switches for the drive boosters are calculated from the rho4 parameters P204, P205 software limit switches in JC, P206 software limit switch tolerance, P207 actual reference point value and P208 reference point offset. The calculation is such that the limit switch values + tolerances set at the rho4 are converted into [units] and transferred to the drive boosters.

Software_Limit_Position = software limit switches (P205/P206) ± limit switch tolerance (P207)

With input of ±999998 in P204, 205 and a MS factor P401 > 100 the limit switch monitoring in the drive, maximum 99999999 is deactivated.

**Automatic_Mode_Velocity_Limit
(Speed limit in automatic mode)**

As speed limit values in automatic mode, the maximum PTP axis speeds defined in P107 * maximum permissible VFACTOR P119 are converted into [RPM] and transferred to the drive boosters.

**Manual_Mode_Velocity_Limit
(Speed limitation in manual mode)**

As speed limit values in manual mode, the JC Jog speeds defined in P114 * maximum permitted VFACTOR P119 are converted into [RPM] and transferred to the drive boosters.

Position_Scaling (Scaling of the actual position return signal)

The transfer value for Position_Scaling (1 to 3) is derived from the value for pulses/rev. entered under P401.

Direction_Flag (Motor/encoder direction of rotation)

The direction of the rotation of the drive is always transferred positively in clock-wise direction (Flag = true). A possibly required reversal of the rotation direction is carried out within the rho4. For further description, see parameter P401, negative MS factor.

 **Further details on drive parameters may be found in the manual: Bosch Servodyn, Operation and Start-up, Servodyn-GC.**

For the definition of the drive parameters in the drive booster, the diagnosis and service system DSS-G (BOSCHTRM) is available.

The definition of the drive parameters via the program BOSCHTRM only applies for the respective drive booster which is connected. For maintaining the drive parameters in case of a drive booster change, the parameters must be entered into the rho. Additionally, the parameter-download must be activated in parameter 601.

Drive parameters Servodyn-GC

P601 Perform parameter transfer

Determines whether the stored drive parameters are transferred during the run-up phase of the rho4.

Input:

- 0: Disable transfer
- 1: Perform transfer

Display on the PHG

```

ROBI_1      MP SET
P601 TRANSFER PARAM.
              1
#
  
```

Entry in converter file

P601.DIAntrPar=1

P602 Drive booster type

With P602 the type of drive booster of each axis is defined.

Number of parameters: one value per axis

Entry	Drive booster type, Bosch designation
1	SM 3,5/8 GC
2	SM 4,7/20 GC
3	SM 6,5/30 GC
4	SM 18/60 GC

Display on the PHG

```

ROBI_1      MP SET
P602 CONTROLLER ID
A01         1
#
  
```

Entry in converter file

P602.ControllerId.Kin1.Axis1=1

Drive parameters Servodyn-GC

P603 Motor type

With P603 the type of motor of each axis is defined.

Number of parameters: one value per axis

Entry:

- See example (the motor type may be found on the Bosch type plate of the respective motors).

Display on the PHG

```
ROBI_1      MP SET
P603 MOTOR ID
A01        SG-A0.002.091
           SG-#
```

Entry in converter file

```
P603.MotorId.Kin1.Axis1=A0.002.091
```

P604 Proportional value of V-controller

In P604 the proportional value of the speed controller is entered.

Parameter number: one value per axis

Permissible values: > 0 to 100000

Input: value in [Nm/(rad/s)]

Display on the PHG

```
ROBI_1      MP SET
P604 VEL. LOOP GAIN
A01        0.005
#
```

Entry in converter file

```
P604.VelGain.Kin1.Axis1=0.005
```

Drive parameters Servodyn-GC

P605 Integral value of V-controller

In P605 the integral value of the speed controller is entered.

Parameter number:	one value per axis
Permissible values:	> 0 to 100000
Input:	value in [s]

Display on the PHG

```
ROBI_1      MP SET
P605 VEL. LOOP CONST
A01         0.001
#
```

Entry in converter file

P605.VelTi.Kin1.Axis1=0.001

P606 Proportional gain of the position controller

In P606 the gain factor of the position controller is entered.

Parameter number:	one value per axis
Permissible values:	> 0 to 100000
Input:	value in [(rad/s)/rad]

Display on the PHG

```
ROBI_1      MP SET
P606 POS. LOOP GAIN
A01         200.000
#
```

Entry in converter file

P606.PropGain.Kin1.Axis1=200.000

Drive parameters Servodyn-GC

P607 Torque limit values

In P607 the torque limit values for the different operating modes, just as Automatic, Manual or Emergency stop are defined.

Parameter number:	three values per axis
Permissible values:	> 0 to 100000
Input:	value in [A]

Display on the PHG

```
ROBI_1      MP SET
P607 CURRENT LIMITS
A01        AUTO: 10.0
#
```

Entry in converter file

P607.AutoTorqueLi.Kin1.Axis1=10.0

Display on the PHG

```
ROBI_1      MP SET
P607 CURRENT LIMITS
A01        MAN.: 5.0
#
```

Entry in converter file

P607.ManTorqueLi.Kin1.Axis1=5.0

Display on the PHG

```
ROBI_1      MP SET
P607 CURRENT LIMITS
A01        EMSTOP: 5.0
#
```

Entry in converter file

P607.EmTorqueLi.Kin1.Axis1=5.0

Drive parameters Servodyn-GC

P608 Emergency stop deceleration ramp

With P608 the deceleration ramp is defined, i.e. how quickly the velocity 0 is reached at Emergency stop.

Parameter number:	one value per axis
Permissible values:	> 0 to 100000
Input:	value in [rad/s ²]

Display on the PHG

```

ROBI_1      MP SET
P608 EM.DECELARATION
A01         200.0
#

```

Entry in converter file

P608.EmDecelerat.Kin1.Axis1=200.0

P609 Speed limit value of braking

The brake is only closed after the speed limit value has fallen below the value entered in P609.

Parameter number:	one value per axis
Permissible values:	> 0 to 100000
Input:	value in [degrees/s resp. mm/s] in relation to the machine axis

Display on the PHG

```

ROBI_1      MP SET
P609 VELOCITY LIMIT
A01         100.0
#

```

Entry in converter file

P609.EmBreakingV.Kin1.Axis1=100.0

Drive parameters Servodyn-GC

P610 Maximum static position error

In P610 the maximum static position error of each axis is entered.

Parameter number: one value per axis

Permissible values: > 0 to 100000

Input: value in [units]

Input 1024: switching off the position error monitoring

Display on the PHG

```
ROBI_1      MP SET
P610 STATIC ERROR
A01        500
#
```

Entry in converter file

P610.StaticErr.Kin1.Axis1=500

P611 Maximum lag error

In P611 the maximum lag error (relative to the motor speed) is entered.

Parameter number: one value per axis

Permissible values: > 0 to 100000

Input: value in [%]

Input 400: switching off lag monitoring

Display on the PHG

```
ROBI_1      MP SET
P611 FOLLOWING ERROR
A01         200
#
```

Entry in converter file

P611.KevSi.Kin1.Axis1=200

Drive parameters Servodyn-GC

P612 Filter band width for torque signal

In P612 the filter band width is defined.

Parameter number:	one value per axis
Permissible values:	> 0 to 100000
Input:	value in [Hz]

Display on the PHG

```

ROBI_1      MP SET
P612 FILT. BANDWIDTH
A01         500.0
#

```

Entry in converter file

P612.FnTorque.Kin1.Axis1=500.0

P613 Damping factor, Zeta

In P613 the damp factor Zeta of the RMC filter of second order for the torque is defined.

Parameter number:	one value per axis
Permissible values:	> 0 to 100000
Input:	value in (dimensionless)

Display on the PHG

```

ROBI_1      MP SET
P613 DAMPING RATIO
A01         0.007
#

```

Entry in converter file

P613.ZTorque.Kin1.Axis1=0.007

Drive parameters Servodyn-GC

P614 Home position offset, position back-signal

In P614 the home position offset is entered.

Parameter number:	one value per axis
Permissible values:	> 0 to 100000
Input:	value in [degrees]

Display on the PHG

```

ROBI_1      MP SET
P614 HOME POS.OFFSET
A01         100.0

#

```

Entry in converter file

P614.HomePosOff.Kin1.Axis1=100.0

P615 Overtemperature protection

P615 defines whether the overtemperature protection is switched On or Off.

Parameter number:	one value per axis
Input:	0: Off 1: On

Display on the PHG

```

ROBI_1      MP SET
P615 OVERTEMP. PROT
A01         1

#

```

Entry in converter file

P615.EnTempProt.Kin1.Axis1=1

Drive parameters Servodyn-GC

10.1 Servodyn-GC-Parameter list

P.-No. rho4-	Notes rho	Servodyn-GC drive booster	BOSCHTRM command
601	Parameter transfer (1 = active) rho ⇒ drive booster		–
602	Drive booster type	Controller type	L – (display)
603	Motor type 1: SM 3,5/8 GC 2: SM 4,7/20 GC 3: SM 6,5/30 GC 4: SM 18/60 GC	Motor ID, No. of motor poles, Calc. factor Kr, Motor current limit, peak torque, R2ph, L2ph	SM
5	CLOCK start time (rho4)	Comm. Cycle period	SC
604	P-value of the velocity controller	Velocity loop gain	SP
605	Integral-action time of the velocity controller	TI	SI
606	Loop gain factor of the position controller	Position loop gain	SG
204	Software limit switch in clockwise direction	Clockwise limit Pos'n	OL
205	Software limit switch in anti-clockwise direction	C.Clockwise limit Pos'n	OL
	Calculated from P204, 205, 206, 207, 208	Pos'n limit switches	OL
607	Current limit value in automatic mode	Auto. current limit	ST
607	Current limit value in manual mode	Man. current limit	ST
607	Current limit value at Emergency stop	Emer. current limit	ST
103	Limit values for speed in automatic mode	Auto. Mode max RPM	SL
114	Limit values for speed in manual mode	Man. Mode max RPM	SL
608	Gradient of the Emergency stop deceleration ramp	Emergency deceleration	SE
609	Speed at which brake closes	Emer. Mode max RPM	SL
610	Max. static position error	Static loop error	SS
611	Lag error relative to motor speed Max lag = motor speed * Kev_SI	Following error	SF
612	Filter band width for torque signal	Torque filter frequency	SW
613	Damp factor (Zeta)	Torque filter Zeta	SZ
401	Scaling of the actual position back-signal 1 = 16384 inc/rev, 2 = 8192 inc/rev 3 = 4096 inc/rev	CAN position scaling	OR
614	Home position offset, position back-signal	Actual position offset	OO
401	Motor/encoder direction of rotation TRUE: Positive direction = clockwise FALSE: Positive direction = anti-clockwise	CAN direction flag	OD
615	Overtemperature protection TRUE: Overtemperature protection active FALSE: Overtemperature protection not active	Thermal protection	OW

Drive parameters Servodyn-GC

Notes:

Drive parameters Servodyn-D

11 Drive parameters Servodyn-D

Group 700	Drive parameters Servodyn-D
P701	Parameter transfer
P702	Primary operating mode
P703	Proportional sensitivity of speed controller
P704	Integral action time of speed controller
P705	Proportional sensitivity-1 of current regulator
P706	Integral action time-1 of current regulator
P707	Proportional sensitivity-2 of current regulator
P708	Integral action time-2 of current regulator
P709	Warning temperature of amplifier
P710	Motor warning temperature
P711	Switch frequency of the power end limit
P712	Kind of shutdown with drive Off
P713	Actual value smoothing interval of Velocity controller
P714	Braking power limitation
P715	Current set value filter: selection of filter type
P716	Current set value filter: limit frequency of low-pass
P717	Current set value filter: Quality band stop
P718	Current set value filter: center frequency band stop
P719	External release of control word
P720	Release delay time SCB
P721	Inport: configuration list
P722	Outport: configuration list
P723	Velocity limit value bipolar
P724	Torque limit value bipolar
P725	Position controller K_V -factor
P726	Torque threshold Mdx
P727	Acceleration bipolar
P728	Monitoring window
P729	Delay Drive On
P730	Delay Drive Off
P731	Positioning acceleration
P732	Factor V-precontrol
P733	DAC channels: configuration list

Drive parameters Servodyn-D

Group 700	Drive parameters Servodyn-D
P734	DAC channel 3: maximum value, offset
P735	DAC channel 4: maximum value, offset
P736	Special function, brake
P737	Command save memory
P738	Encoder data
P739	Function clearing
P740	Loadcompensation Torque
P741	Loadcompensation Velocity Limit
P742	Reserve 5, INTEGER
P743	Thermal motor protection factor
P744	Reserve 7, INTEGER
P745	Motor switch off temperature

Further information on the significance of the individual parameters and their value ranges are to be found in the manual Servodyn-D with CAN bus parameter description. As sometimes binary entries are required, the drive parameters (P700) can only be entered into the rho4 with the help of the rho4-specific parameter list created by the DSS.

 **It is not checked in the machine parameter program whether the values of the individual parameters are permitted. This is carried out during the download of the drive. If a parameter value is out of the permitted range, the rho4 puts out a corresponding error message under Mode 7.2.**

Drive parameters Servodyn-D

P701 Parameter transfer

Permitted values 0/1

Input	0	Switch off transfer
	1	Perform transfer

Display on the PHG

```
ROBI_1      MP SET
P701 TRANSFER PARAM.
              1
#
```

Entry in converter file

P701.DIAntrPar=1

P702 Primary operating mode

Display on the PHG

```
ROBI_1      MP SET
P702 PRIM. OP. MODE
A01         1
#
```

Entry in converter file

P702.PrimOpMod.Kin1.Axis1=3

P703 Proportional sensitivity of speed controller

Display on the PHG

```
ROBI_1      MP SET
P703 VEL.LOOP P:GAIN
A01         50.00
#
```

Entry in converter file

P703.VelProp.Kin1.Axis1=50.00

Drive parameters Servodyn-D

P704 Integral action time of speed controller

Display on the PHG

```
ROBI_1      MP SET
P704 VEL.LOOP I.AC.T
A01      10.00

#
```

Entry in converter file

P704.VelIntTim.Kin1.Axis1=10.00

P705 Proportional sensitivity-1 of current regulator

Display on the PHG

```
ROBI_1      MP SET
P705 PRO.GAIN1 C.REG
A01      1000.00

#
```

Entry in converter file

P705.C1PropReg.Kin1.Axis1=1000.00

P706 Integral action time-1 of current regulator

Display on the PHG

```
ROBI_1      MP SET
P706 I.AC.T.1 C.REG
A01      100000

#
```

Drive parameters Servodyn-D

Entry in converter file

P706.C1IntTime.Kin1.Axis1=100000

P707 Proportional sensitivity-2 of current regulator

Display on the PHG

```
ROBI_1      MP SET
P707 PRO.GAIN2 C.REG
A01      1000.00

#
```

Entry in converter file

P707.C2PropReg.Kin1.Axis1=1000.00

P708 Integral action time-2 of current regulator

Display on the PHG

```
ROBI_1      MP SET
P708 I.AC.T.2 C.REG.
A01      100000

#
```

Entry in converter file

P708.C2IntTime.Kin1.Axis1=100000

P709 Warning temperature of amplifier

Display on the PHG

```
ROBI_1      MP SET
P709 AMPL. WARN TEMP
A01      75.00

#
```

Entry in converter file

P709.AmplWTemp.Kin1.Axis1=75.00

Drive parameters Servodyn-D

P710 Warning temperature of motor

Display on the PHG

ROBI_1	MP SET
P710 MOTOR WARN.TEMP	
A01	145.00
#	

Entry in converter file

P710.MotoWTemp.Kin1.Axis1=145.00

P711 Switch frequency of power end stage

Display on the PHG

ROBI_1	MP SET
P711 SW.FRQ.PWR.OUTP	
A01	8000
#	

Entry in converter file

P711.PowOutFrq.Kin1.Axis1=8000

P712 Type of shutdown with drive Off

Display on the PHG

ROBI_1	MP SET
P712 STOP-METH.D.OFF	
A01	0
#	

Entry in converter file

P712.DriveOffM.Kin1.Axis1=0

Drive parameters Servodyn-D

P713 Actual value smoothing interval of velocity controller

Display on the PHG

```
ROBI_1      MP SET
P713 A.V.S.I.VEL REG
A01      250.00

#
```

Entry in converter file

P713.VelSmoVal.Kin1.Axis1=250.00

P714 Braking power limitation

Display on the PHG

```
ROBI_1      MP SET
P714 BRAKE-CURR.LIM
A01      100.00

#
```

Entry in converter file

P714.LimBreakC.Kin1.Axis1=100.00

☞ Parameters P715, P716, P717, P718, P721 and P733 are multistage parameters. With the index N these axes are partitioned into four further stages. The only exception is parameter P733. It is only partitioned into two stages.

P715 Current set value filter: selection of filter type

Display on the PHG

```
ROBI_1      MP SET
P715 FILTER:FILT.TYP
A01 N1:      0

#
```

Entry in converter file

P715.CFilType.Kin1.Axis1.Value1=0

Drive parameters Servodyn-D

Example for entry of index**Display on the PHG**

```
ROBI_1      MP SET
P715 FILTER:FILT.TYP
A01 N2:    1
#
```

Entry in converter file

P715.CFilType.Kin1.Axis1.Value2=1

P716 Current set value filter: limit frequency of low pass**Display on the PHG**

```
ROBI_1      MP SET
P716 FILT.:LIM.FR LP
A01 N1:    2000.00
#
```

Entry in converter file

P716.CLimFreq.Kin1.Axis1.Value1=2000.00

P717 Current set value filter: quality band disable**Display on the PHG**

```
ROBI_1      MP SET
P717 FILT.:QUAL.B.EL
A01 N1:    1.00
#
```

Entry in converter file

P717.CQuaBand.Kin1.Axis1.Value1=1.00

Drive parameters Servodyn-D

P718 Current set value filter: center frequency of band disable

Display on the PHG

```
ROBI_1      MP SET
P718 FILT.:CFRQ.B.EL
A01 N1:    2000.00

#
```

Entry in converter file

P718.CCentFrq.Kin1.Axis1.Value1=2000.00

P719 Control word of external release

Display on the PHG

```
ROBI_1      MP SET
P719 COMM.EXT.RELEAS
A01         0

#
```

Entry in converter file

P719.ExtReleas.Kin1.Axis1=0

P720 Release delay time SCB

Display on the PHG

```
ROBI_1      MP SET
P720 SCB EN.DEL.TIME
A01         200

#
```

Entry in converter file

P720.DelayTime.Kin1.Axis1=200

Drive parameters Servodyn-D

P721 Inport: configuration list

Display on the PHG

```
ROBI_1      MP SET
P721 INP:KONF.-LIST
A01  N1:    0

#
```

Entry in converter file

P721.InConfLi.Kin1.Axis1=0

P722 Outport: configuration list

Display on the PHG

```
ROBI_1      MP SET
P722 OUTP:KONF.-LIST
A01  N1:    0

#
```

Entry in converter file

P722.OutConfLi.Kin1.Axis1=0

P723 Velocity limit value bipolar

Display on the PHG

```
ROBI_1      MP SET
P723 BIP.VEL.LIM.VAL
A01          100000

#
```

Entry in converter file

P723.KinVelLimVal.Kin1.Axis1=100000

Drive parameters Servodyn-D

P724 Torque limit value bipolar

Display on the PHG

```
ROBI_1      MP SET
P724 BIP.TOR.LIM.VAL
A01         300.00

#
```

Entry in converter file

P724.TqLimVal.Kin1.Axis1.Value1=300.00

P725 Position controller K_V -factor

Display on the PHG

```
ROBI_1      MP SET
P725 POS.LOOP KV-FAC
A01         1.00

#
```

Entry in converter file

P725.KvFactor.Kin1.Axis1=1.00

P726 Torque threshold Mdx

Display on the PHG

```
ROBI_1      MP SET
P726 TORQ.THRESH.MDX
A01         100.00

#
```

Entry in converter file

P726.TqThresh.Kin1.Axis1=100.00

Drive parameters Servodyn-D

P727 Acceleration bipolar

Display on the PHG

```
ROBI_1      MP SET
P727 BIP. ACCELER.
A01         100000

#
```

Entry in converter file

P727.BipolAccl.Kin1.Axis1=100000

P728 Monitoring window

Display on the PHG

```
ROBI_1      MP SET
P728 MONITOR WINDOW
A01         120.00

#
```

Entry in converter file

P728.MonitWind.Kin1.Axis1=120.00

P729 Delay drive On

Display on the PHG

```
ROBI_1      MP SET
P729 DRIVE ON DELAY
A01         0

#
```

Entry in converter file

P729.DrOnDelay.Kin1.Axis1=0

Drive parameters Servodyn-D

P730 Delay drive Off

Display on the PHG

```
ROBI_1      MP SET
P730 DRIVE OFF DELAY
A01         0

#
```

Entry in converter file

P730.DrOfDelay.Kin1.Axis1=0

P731 Positioning acceleration

Display on the PHG

```
ROBI_1      MP SET
P731 POSIT. ACCELER.
A01         1000.00

#
```

Entry in converter file

P731.PositAcc.Kin1.Axis1=1000.00

P732 Factor V-precontrol

Display on the PHG

```
ROBI_1      MP SET
P732 V.FEED FORW.CO.
A01         80.00

#
```

Entry in converter file

P732.VelFFCoef.Kin1.Axis1=80.00

Drive parameters Servodyn-D

P733 DAC-channels: configuration list

Display on the PHG

```
ROBI_1      MP SET
P733 DAC CH:CONF.LIS
A01  N1:    0
#
```

Entry in converter file

P733.DacConfL.Kin1.Axis1.Value1=0

P734 DAC-channel 3: maximum value, offset

Display on the PHG

```
ROBI_1      MP SET
P734 DAC C3:MAX.VAL.
A01          0.00
#
```

Entry in converter file

P734.DacCh3Max.Kin1.Axis1=0.00

P735 DAC-channel 4: maximum value, offset

Display on the PHG

```
ROBI_1      MP SET
P735 DAC C4:MAX.VAL.
A01          0.00
#
```

Entry in converter file

P735.DacCh4Max.Kin1.Axis1=0.00

Drive parameters Servodyn-D

P736 Special function brake

Display on the PHG

```
ROBI_1      MP SET
P736 SPEC-FCT BRAKE
A01         0

#
```

Entry in converter file

P736.SpFctBrak.Kin1.Axis1=0

P737 Save memory command

Display on the PHG

```
ROBI_1      MP SET
P737 MEMORY SAVE
A01         0

#
```

Entry in converter file

P737.MemSavCom.Kin1.Axis1=0

P738 Encoder data

Display on the PHG

```
ROBI_1      MP SET
P738 ENCODER DATA
A01         0

#
```

Entry in converter file

P738.EncoderData.Kin1.Axis1=0

Drive parameters Servodyn-D

P739 Function enable

Display on the PHG

```
ROBI_1      MP SET
P739 FUNCTION ENABLE
A01         0
#
```

Entry in converter file

P739.FunctionEnable.Kin1.Axis1=0

P740 Loadcompensation Torque

Display on the PHG

```
ROBI_1      MP SET
P740 LOADCOMP.-TOR.
A01         0
#
```

Entry in converter file

P740.LoadcompensationTorque.Kin1.Axis1=0

P741 Loadcompensation Velocity Limit

Display on the PHG

```
ROBI_1      MP SET
P741 LOADCOMP.-V
A01         0
#
```

Entry in converter file

P741.LoadcompensationVLimit.Kin1.Axis1=0

Drive parameters Servodyn-D

P742 Reserve 5, INTEGER

Display on the PHG

```
ROBI_1      MP SET
P742 RESERVE 5 INT
A01        0

#
```

Entry in converter file

P742.Sd_Reserve5.Kin1.Axis1=0

P743 Thermal motor protection factor

Display on the PHG

```
ROBI_1      MP SET
P743 MOTOR-TEMP-FAC
A01          0.00

#
```

Entry in converter file

P743.ThermMotorProtect.Kin1.Axis1=0.00

P744 Reserve 7, INTEGER

Display on the PHG

```
ROBI_1      MP SET
P744 RESERVE 7 INT
A01        0

#
```

Entry in converter file

P744.Sd_Reserve7.Kin1.Axis1=0

Drive parameters Servodyn-D

P745 Motor switch-off temperature

The entry is in °C.

Display on the PHG

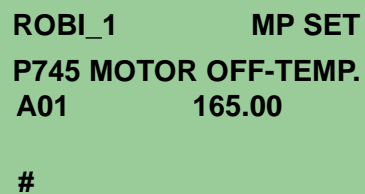

ROBI_1 MP SET
P745 MOTOR OFF-TEMP.
A01 165.00

#

Entry in converter file

P745.MotorMaxTemp.Kin1.Axis1=165.00

Drive parameters Servodyn-D

11.1 Servodyn-D - Parameter list

The following table contains all parameters which can be loaded into the drive by the rho4 via the CAN bus. The 1st column contains the rho4 parameter number, the 2nd column the ID-number of the DSS. The column valency indicates the data type and the column group the functional relationship of the parameter.

P.-No. rho4	ID-No. DSS	Valency	Parameter name	Group
5	S-0-0002	integer	Cycle time	Interface
702	S-0-0032	integer	Primary operating mode	Drive operating mode
703	S-0-0100	real	Proportional sensitivity of speed controller	Controller, speed
704	S-0-0101	real	Integral action time of speed controller	Controller, speed
705	S-0-0106	real	Proportional sensitivity-1 of current regulator	Controller, current
706	S-0-0107	integer	Integral action time-1 of current regulator	Controller, current
707	S-0-0119	real	Proportional sensitivity-2 of current regulator	Controller, current
708	S-0-0120	integer	Integral action time-2 of current regulator	Controller, current
709	S-0-0200	real	Warning temperature of amplifier	Diagnosis, amplifier
710	S-0-0201	real	Warning temperature of motor	Diagnosis, motor
711	P-0-0001	integer	Switch frequency of power end stage	Amplifier
712	P-0-0004	integer	Type of shutdown for drive Off	Drive Off
713	P-0-0013	real	Act. value smoothing interval of Velocity controller	Controller, speed, filter
714	P-0-0027	real	Braking power limitation	Drive Off
715	P-0-0120	integer	Current set value filter: selection of filter type (4 elements)	Current set value filter
716	P-0-0121	real	Current set value filter: limit frequency low-pass (4 elements)	Current set value filter
717	P-0-0122	real	Current set value filter: qual. band disable (4 elem.)	Current set filter
718	P-0-0123	real	Current set value filter: center frequency band disable (4 elements)	Current set value filter
719	P-0-0125	integer	Control word ext. release	Drive Off
720	P-0-0505	integer	Release delay SCB	Drive On
721	P-0-2000	integer	Inport: configuration list (4 elements)	I/O signals
722	P-0-2002	integer	Outport: configuration list	I/O signals
723	S-0-0091	real	Velocity-limit value bipolar	Controller, speed
724	S-0-0092	real	Torque-limit value bipolar (4 elements)	Controller, speed
725	S-0-0104	real	Position controller K_V -factor	Controller, position
726	S-0-0126	real	Torque threshold Mdx	Diagnosis, torque

Drive parameters Servodyn-D

P.-No. rho4	ID-No. DSS	Valency	Parameter name	Group
727	S-0-0138	real	Acceleration bipolar	Acceleration
728	S-0-0159	real	Monitoring window	Controller, speed
729	S-0-0206	integer	Delay drive On	Drive On
730	S-0-0207	integer	Delay drive Off	Drive Off
731	S-0-0260	real	Positioning acceleration	Controller, position
732	P-0-0500	real	Factor velocity precontrol	Controller, position
733	P-0-2010	integer	DAC-channels: configuration list (2 elements)	Analogous outputs
734	P-0-2014	real	DAC-channel 3: maximum value	Analogous outputs
735	P-0-2015	real	DAC-channel 4: maximum value	Diagnosis, analogous outputs
736	P-0-0489	integer	Special function brake	Drive Off
737	S-0-0264	integer	Save memory command	Save parameter
738	P-0-0070	integer	Encoder data	
739	P-0-0090	integer	Function clearing	
740	P-0-0581	integer	Loadcompensation Torque	
741	P-0-0582	integer	Loadcompensation Velocity Limit	
742	P-0-0053	integer	Bimetall function	
743	P-0-0200	real	Thermic Motor Protection Factor	
744	S-0-0257	integer	Reserve 7 INTEGER	
745	S-0-0204	real	Motor switch-off temperature	Diagnosis, motor

Table of parameters

12 Table of parameters

The following table is determined for entering your personal settings.
Print this list and enter your system-specific values.

General system parameters									
P1	Number of kinematics								
P2	Machine configuration								
P3	Reserved								
P4	Parity for INTEGER inputs at the interface <small>(0 = none, 1 = odd, 2 = even)</small>							ms	
P5	CLOCK start time								
P6	Runtime monitoring (ms) [min. 10 * clock]					P1 =		P2 =	
P7	Reserved								
P8	Strobe times for INTE- GER user outputs				Output 1 =	Output 2 =	Output 3 =	Output 4 =	
					Output 5 =	Output 6 =	Output 7 =	Output 8 =	
					Output 9 =	Output 10 =	Output 11 =	Output 12 =	
					Output 13 =	Output 14 =	Output 15 =	Output 16 =	
P9	Strobe time for system outputs (ms)								
P10	Language selection (0 = German, 1 = English)								
P11	Number of probes								
P12	Reserved								
P13	Reserved								
P14	Reserved								
P15	Reserved								
P16	IRDATA stack size							kbytes	
P17	Reserved								
P18	Reserved								
P19	Definition of the PHG key groups								
P20	I/O assembly configuration								
P21	PLC para- meters	Time mon.		INTER- BUS-S	BEG. I:	End. I:	BEG. O:	End. O:	
P22	Global range limit	AFactor			Min-value:		Max-value:		
		DFactor			Min-value:		Max-value:		

Table of parameters

General system parameters								
P23	Global range limit	VFactor			Min-value:		Max-value:	
P24	Deletion of user outputs delete until user outp.							
P25	Reset behavior of the A/D/V-factors						global factors	kin.-dep. factors
						INITIAL POSITION		
						AUTO ==> MANUAL		
						MANUAL ==> AUTO		
						PROCESS SELECTION		
P26	Reserved							
P27	Strobe INTEGER inputs						(With = 0, without = 1)	
P28	Display of options available (only display)							
P29	Reserved							
P30	I/O-configuration CAN bus					Numb. dig. inp.-blocks		
						Numb. dig. outp.-blocks		
						Numb. SrCan-Module		
						CANopen download		
						Protocole type	CAN1:	CAN2:
						Baud rate	CAN1:	CAN2:
P31	Address ranges of CAN inputs		Bus No.	EA type	Dss Ref	Start addr.	Block length	Identifier
		Block 1						
		Block 2						
		Block 3						
		Block 4						
		Block 5						
		Block 6						
		Block 7						
		Block 8						
		Block 9						
		Block 10						

Table of parameters

General system parameters									
P32	Address ranges of CAN outputs		Bus-No.	EA type	Dss Ref	Start addr.	Block length	Identifier	
		Block 1							
		Block 2							
		Block 3							
		Block 4							
		Block 5							
		Block 6							
		Block 7							
		Block 8							
		Block 9							
		Block 10							
P33	Reserved								
P34	Number of characters in output buffer					(Standard = 16, Entry: 1 to 16)			
P35	PHG Mode					(PHG 2000 Mode=0, PHG 3 Mode=1)			
P36	Multi-function inputs (byte address) Multi-function outputs (byte address) Multi-function2inputs (byte address) Multi-function2outputs (byte address)								
P37	Electronic type plate					Baudrate			
P38	Sercos interface					Download			
P39	Workspace monitoring					Workspace No.			
						Kinematic			
						Xmin	Xmax		
						Ymin	Ymax		
						Zmin	Zmax		
						Workspace No.			
						Kinematic			
						Xmin	Xmax		
						Ymin	Ymax		
						Zmin	Zmax		

Table of parameters

P100 Speeds			MA_1			MA_2		
P101	Nominal lag in degrees resp. mm							
P102	Maximum path speed in mm/s							
P103	Maximum axis speed in mm/s							
P104	Slope acceleration PTP in degrees/s ² resp. mm/s ²							
P105	Slope point PTP in JC in degrees/s resp. mm/s							
P106	Slope-point path operation in mm/s							
P107	Slope-point jog in WC in mm/s	Block slope						
		Program slope						
P108	Referencing speed in degrees/s resp. mm/s							
P109	1. reduced referencing speed in degrees/s resp. mm/s							
P110	2. reduced referencing speed in degrees/s resp. mm/s							
P111	Jog-speed WC slow in mm/s							
P112	Jog-speed WC fast in mm/s							
P113	Jog-speed JC slow in degrees/s resp. mm/s							
P114	Jog-speed JC fast in degrees/s resp. mm/s							
P115	Incremental steps WC in mm	Step meas. 1						
		Step meas. 2						
P116	Incremental steps JC in mm	Step meas. 1						
		Step meas. 2						
P117	A/D-Slope Jog in WC in mm/s ²							
P118	Range limits for	AFACTOR	min:	max:	min:	max:		
		DFACTOR	min:	max:	min:	max:		
P119	Range limits for	VFACTOR	min:	max:	min:	max:		
P120	On-status slope (0 = block slope, 1 = program slope)							
P121	Slope form (0 = ramp, 1 = sin ²)							
P122	Acceleration change times PTP in JC	A						
	Deceleration change times PTP in JC	D						
P123	Acceleration change times for Jog in WC	A						
	Deceleration change times for Jog in WC	D						
P124	Acceleration change times for path operation	A						
	Deceleration change times for path operation	D						
P125	Switch-off time of the interpolator-stop-monitoring							
P126	Switch-off time of the standstill monitoring							
P127	In-position-range of the standstill monitoring							
P128	A/D slope Jog in JC in degrees/s resp. mm/s	A						
		D						

Table of parameters

P100 Speeds			MA_1			MA_2		
P129	Slope-point Jog in JC in degrees/s resp. mm/s							
P130	Acceleration change times for Jog JC	A						
	Deceleration change times for Jog JC	D						

Table of parameters

P200 Positions		MA_1			MA_2			
P201	In-position-range							
P202	Positive software limit switches for WC in mm resp. degrees							
P203	Negative software limit switches for WC in mm resp. degrees							
P204	Positive software limit switches for JC in mm resp. degrees							
P205	Negative software limit switches for JC in mm resp. degrees							
P206	Software limit switch tolerance in mm resp. degrees							
P207	Reference point actual value in mm resp. degrees							
P208	Reference point offset in mm resp. degrees							
P212	Presetting of passing in mm resp. degrees	radius						
			factor					
P213	Passing distances in mm resp. degrees							
P214	Passing type (axis-criterion = 0, world-criterion = 1)							

Table of parameters

P300 Kinematic parameters		MA_1			MA_2		
P301	Kinematic name (max. 12 ASCII characters)						
P302	Axis number of the kinematic						
P303	Axis type (0 = normal-, 1 = manual , 3 = endless-axis)						
P304	Axis name (max. three ASCII characters)						
P305	Coordinate name (max. three ASCII characters)						
P306	Selection of robot type (transformation)						
	Referencing of all axes by ambiguity (Y/N)						
	Read POS with coordinate change (Y/N)						
	Read POS-(0 = set position, 1 = actual position) (Y/N)						
	Endless axes in main range (Y/N)						
	WC axis monitoring (0, 1, 2, 3)						
P307	Axis length (in mm)						
P308	Coupling factors (values between 0.0 and 1.0)	01:	02:	01:	02:		
		03:	04:	03:	04:		
		05:	06:	05:	06:		
		07:	08:	07:	08:		
P309	Flange coordinate system resp. (_X,_Y,_Z)						
	Mounting inaccuracy (_O1,_O2,_O3)						
P310	Offset of the world coordinate system (in mm) (X_0,Y_0,Z_0)						
P311	Modulo value for endless-axes (in mm resp. degrees)						
P312	Reserved						
P313	Workpiece coordinate system (_x,_y,_z,_a,_b,_c)						
P314	Series number of electronic type plate						

Table of parameters

P400 Measuring system parameters		MA_1		MA_2	
P401	Equipment of the measuring system board				
	Servo board				
	Slot number				
	Module number				
	Module input				
	Drive type				
	Numb. /rev.				
	Pos. offset				
	Marker distance				
	Ref. mode				
	Gear factor				
	Pulses/rev.				
	Meas. system factor				
	Set value output No.				
P402	Direction of reference point travel (-1 = negative, +1 = positive, 0 = no reference points)				
P403	Effectiveness of reference point switches (-1 = falling edge, +1 = rising edge, 0 = no switches)				
P404	Number of analog outputs				
P405	Assignment of the analog outputs	Outp. 1	Outp. 2	Outp. 3	Outp. 4
	Assignment				
	Start address				
	Format				
	Nominal value				
	Voltage offset				
P406	Number of analog inputs				
P407	Assignment of the analog inputs	Inp. 1	Inp. 2	Inp. 3	Inp. 4
	Assignment				
	Start address				
	Format				
	Nominal value				

Table of parameters

P500 Belt parameters		MA_1			MA_2		
P501	Number of belts						
P503	Belt coupling factor						
P505	Limit values of belt						
P506	Belt name (max. 12 ASCII characters)						
P507	Belt time offset						
P508	Belt simulator velocity						
P509	Belt actual value/set value						

Table of parameters

P600 Drive parameters Servodyn-GC		MA_1			MA_2		
P601	Perform transfer (Yes = 1, no = 0)						
P602	Amplifier type						
P603	Motor type						
P604	Proportional value of speed controller						
P605	Integral-action time of speed controller						
P606	Amplification factor of the position controller						
P607	Torque limit values	Automatic					
		Manual					
		Emer. Stop					
P608	Emergency Stop deceleration ramp						
P609	Speed limit values						
P610	Maximum static position error						
P611	Maximum lag error						
P612	Filter band-width, torque signal						
P613	Damping factor, Zeta						
P614	Home position offset, position back-signal						
P615	Overtemperature protection(On = 1, Off = 0)						

Table of parameters

P700 Drive parameters Servodyn-D		MA_1			MA_2		
P701	Perform transfer						
P702	Primary operating mode						
P703	Proportional sensitivity of speed controller						
P704	Integral action time of speed controller						
P705	Proportional sensitivity-1 of current regulator						
P706	Integral action time-1 of current regulator						
P707	Proportional sensitivity-2 of current regulator						
P708	Integral action time-2 of current regulator						
P709	Amplifier warning temperature						
P710	Motor warning temperature						
P711	Switch frequency of the power end limit						
P712	Kind of shutdown with drive Off						
P713	Actual value of smoothing interval, velocity controller						
P714	Braking power limitation						
P715	Current set-value filter: selection of filter type						
P716	Current set-value filter: limit frequency of low pass						
P717	Current set-value filter: quality band lock						
P718	Current set-value filter: center frequency band lock						
P719	Control word of external release						
P720	Release deceleration SCB						
P721	Inport: configuration list						

Table of parameters

P700 Drive parameters Servodyn-D		MA_1			MA_2		
P722	Outport: configuration list						
P723	Speed limit value bipolar						
P724	Torque limit value bipolar						
P725	Position controller K_V .factor						
P726	Torque threshold Mdx						
P727	Acceleration bipolar						
P728	Monitoring window						
P729	Delay Drive On						
P730	Delay Drive Off						
P731	Positioning acceleration						
P732	Factor of speed pre-control						
P733	DAC-channels: configurations list						
P734	DAC-channel 3: maximum value						
P735	DAC-channel 4: maximum value						
P736	Special function, brake						
P737	Save memory						
P738	Encoder data						
P739	Function enable						
P740	Loadcompensation Torque						
P741	Loadcompensation Velocity Limit						
P742	Reserve 5, INTEGER						
P743	Thermal motor protection factor						
P744	Reserve 7, INTEGER						
P745	Motor switch-off temperature						

Appendix

A Appendix

A.1 Abbreviations

Abbreviation	Meaning
BAPS3	Programming language; Bewegungs- und Ablaufprogrammiersprache, Version 3; programming language
C:	Hard disk drive
CAN	Controller Area Network
DAC	Digital-analog converter
EEPROM	Electronically erasable programmable read-only memory
EGB	Elektrostatic sensitive components
ESD	Electrostatic discharge
LF	Line feed
MPP	Machine parameter program
MSD	Machine state display
PCL	Memory-programmable control
PE	Protective earth
PHG	Hand-held programming unit
POS	Actual position
PTP	Point to point
RC	Robot control
ROD	Incremental encoder
RPM	Rounds per minute
ROPS4	Robot programming system for rho4
TCP	Tool center point
WC	World coordinates

Appendix

A.2 Index

A

A/D slope acceleration Jog, WC, 5–13
A/D changes times, Jog, JC, 5–24
A/D–slope, Jog, JC, 5–23
acceleration
 change times
 Jog and WC, 5–20
 path operation, 5–21
 PTP, 5–20
 form, 5–16
acceleration bipolar, 11–12
actual value smoothing interval of velocity controller,
 11–7
address ranges of the CAN inputs, 4–23
address ranges of the CAN outputs, 4–27
axis controller type, 7–10
axis length, 7–6
axis names, 7–3
axis type, 7–2

B

belts
 actual value/set value, 9–5
 direction cosine, 9–2
 name, coordinate name, 9–3
 number of, 9–2
 simulator velocity, 9–4
faktor, 5–14
braking power limitation, 11–7

C

CAN, pulses per rotation, 8–11
CAN interface, 8–4
changing machine parameters, 3–3
changing the password, 3–5
Clock Start time (clocked operation), 4–5
command outputs, assignment, 8–13
control word of external release, 11–9
coordinate names, 7–3
coupling factors, 7–6
current set value filter: center frequency of band lock,
 11–9
current set value filter: limit frequency of low pass,
 11–8
current set value filter: Quality band lock, 11–8
current set value filter: selection of filter type, 11–7

D

DAC–channel 3: maximum value, offset, 11–14
DAC–channel 4: maximum value, offset, 11–14
DAC–channels: configuration list, 11–14
Deceleration factor, 5–14

delay drive Off, 11–13
delay drive On, 11–12
deletion of user outputs, 4–16
diagnosis, 3–3
display of available options, 4–18
Documentation, 1–7
drive parameter
 booster type, 10–3
 carry out download, 10–3
 damping factor ZETA, 10–9
 Emergency stop deceleration ramp, 10–7
 filter band width for torque signal, 10–9
 home position offset, 10–10
 integral value V–controller, 10–5
 max. static position error, 10–8
 maximum lag error, 10–8
 motor type, 10–4
 overtemperature protection, 10–10
 prop. gain of the position controller, 10–5
 proportional value V–controller, 10–4
 torque limit values, 10–6
drive type, 8–7
Dss reference, 8–13

E

electronic type plate, 4–34
EMC Directive, 1–1
EMERGENCY–STOP devices, 1–5
Encoder data, 11–15
ESD
 Electrostatic discharge, 1–6
 grounding, 1–6
 workplace, 1–6
ESD–sensitive components, 1–6

F

factor V–precontrol, 11–13
flange coordinate system, 7–7
Floppy disk drive, 1–7
Format, 8–19, 8–22
Function enable, 11–16

G

gear factor, 8–10
Grounding bracelet, 1–6

H

Hard disk drive, 1–7

I

I/O configuration of the CAN bus, 4–21
I/O–assembly group configuration, 4–12

Appendix

incremental measuring system, 8–4
 marker distance, 8–4
 increments
 JC, 5–13
 WC, 5–12
 inport: configuration list, 11–10
 inpos, range, 6–2
 inpos range, 5–23
 integral action time of speed controller, 11–4
 integral action time–1 of current regulator, 11–4
 integral action time–2 of current regulator, 11–5
 IRDATA stack size, 4–10

K

key assignment, 3–1
 kinematic change in the MPP, 3–6
 kinematic
 axis number of, 7–2
 name, 7–1
 kinematics number, 4–3

L

language selection, 4–9
 limit values for belt counter, 9–3
 Loadcompensation Torque, 11–16
 Loadcompensation Velocity Limit, 11–16
 Low-Voltage Directive, 1–1

M

machine configuration, 4–3
 machine parameters, change of, 3–3
 marker distance, glass scales, 8–4
 max. slope acceleration, PTP, 5–5
 maximum axis speed PTP, 5–4
 maximum path speed, 5–3
 measuring system board, equipment, 8–1
 module number, 8–3
 Modules sensitive to electrostatic discharge. *Siehe*
 ESD-sensitive components
 Modulo value, 8–10
 modulo value for endless axes, 7–9
 monitoring window, 11–12
 motor switch-off temperature, 11–18
 motor warning temperature, 11–6
 mounting position, offset, 7–8
 multi-function I/O, 4–31

N

nominal lag, 5–2
 Nominal value, 8–23
 number of characters with a set handshake, 4–30
 number of probes, 4–10
 number of the PHG key groups, 4–10

O

Offset, 8–20
 ON condition, slope mode, 5–15
 output: configuration list, 11–10

P

paging, 3–2
 parameter transfer, 11–3
 parity for INTEGER-inputs at the interface, 4–4
 passing distances, 6–7
 presettings, 6–6
 passing type, 6–7
 password, 3–2
 change, 3–5
 PHG, 3–1–3–5
 PHG mode, 4–30
 PHG2000, 3–1
 PLC parameter, 4–12
 position controller KV-factor, 11–11
 positioning acceleration, 11–13
 Preparation logic, 4–7
 primary operating mode, 11–3
 proportional sensitivity of speed controller, 11–3
 proportional sensitivity–1 of current regulator, 11–4
 proportional sensitivity–2 of current regulator, 11–5
 pulse quadruplication, 8–12

Q

Qualified personnel, 1–2

R

range
 AFACTOR/DFACTOR, 5–14
 VFACTOR, 5–15
 range of global A-/DFACTOR, 4–14
 range of global VFACTOR, 4–15
 reference point
 1st reduced speed, 5–9
 2nd reduced speed, 5–10
 actual value, 6–5
 direction, travel, 8–15
 offset, 6–6
 schematic illustration, 6–5
 switch, effectiveness, 8–16
 referencing mode, 8–9
 referencing speed, 5–7
 Release, 1–8
 release delay time KSB, 11–9
 reset of the A/D/V-factors, 4–16
 rotation, number of rotations, 8–8
 runtime monitoring, 4–7

S

Safety instructions, 1–4

Appendix

Safety markings, 1–3
save memory command, 11–15
Sercos axis number, 8–6
Sercos–Interface, 4–35
Sercos–Ring, 8–3
series number of electronic type plate, 7–11
servo board, 8–2
Servo loop logic, 4–7
Servodyn–GC – parameter list, 10–11
sin2–similar, 5–16
slope point, Jog, JC, 5–24
slope point Jog in world coordinates WC, 5–7
slope point path operation, 5–6
slope point PTP in machine coordinates JC, 5–6
slot number, 8–2
software limit switch, tolerance, 6–4
software limit switches
 negative
 JC, 6–4
 WC, 6–2
 positive
 MK, 6–3
 WC, 6–2
Spare parts, 1–6
special function brake, 11–15
speed, JOG
 JC fast, 5–12
 JC slow, 5–11
 WC fast, 5–11
 WC slow, 5–10
Speed factor, 5–15
speed limit value of braking, 10–7
Standard operation, 1–1
strobe INTEGER inputs, 4–18
strobe time system outputs, 4–9
strobe times, 4–8
switch frequency of power end stage, 11–6
switch–off time
 interpolator stop, 5–22
 standstill monitoring, 5–22

T

Test activities, 1–5
Tool Center Point, 5–3
torque limit value bipolar, 11–11
torque threshold Mdx, 11–11
Trademarks, 1–8
transformation, selection, 7–4
Transmitter path /Rotation, 8–8
type of shutdown with drive Off, 11–6

V

velocity limit value bipolar, 11–10

W

warning temperature of amplifier, 11–5
Workspace monitoring, 4–36

Z

zero point offset, 8–9

Bosch Rexroth AG
Electric Drives and Controls
P.O. Box 13 57
97803 Lohr, Germany
Bgm.-Dr.-Nebel-Str. 2
97816 Lohr, Germany
Phone +49 (0)93 52-40-50 60
Fax +49 (0)93 52-40-49 41
service.svc@boschrexroth.de
www.boschrexroth.com

